

# BRAIN STATE AND PLASTICITY: AN INTEGRATION OF THE RECIPROCAL INTERACTION MODEL OF SLEEP CYCLE OSCILLATION WITH ATTENTIONAL MODELS OF HIPPOCAMPAL FUNCTION \*

J. A. HOBSON<sup>1</sup> AND N. A. SCHMAJUK<sup>2</sup>

<sup>1</sup> *Laboratory of Neurophysiology, Department of Psychiatry, Harvard Medical School, Boston, MA 02115, U.S.A.* and <sup>2</sup> *Department of Psychology, Northwestern University, Evanston, Illinois, 60201, USA*

## INTRODUCTION

Flicker *et al.* (16) suggested that both sleep and learning phenomena are under the control of common neurophysiological mechanisms. They pointed out that although the sleeping state precludes the acquisition of new information, experimental evidence from evoked potential studies shows that information transmission in sensory systems is often unaffected during sleep, an indication that a higher threshold for sensory inputs is not responsible for the absence of learning. Flicker *et al.* (16) suggested that a mechanism operating in parallel with primary sensory pathways must be involved, and proposed that aminergic neurons of the locus coeruleus (LC) and raphe nuclei (RN) participate in both the control of sleep state and learning processes.

Since simultaneous analysis of data coming from the sleep and learning literature might unveil functions of brain structures participating in both phenomena, the present paper reviews the role of the aminergic system in sleep and learning and its action on the hippocampus, an area that traditionally has been proposed to be involved in the storage and retrieval of information.

## BEHAVIORAL STATES

The state of an organism is defined as a "recurring, temporally enduring constellation of values of a set of indicator variables of the organism" (20). Behavioral states can be defined by indicators such as stimulus threshold, electroencephalographic (EEG) voltage, rapid eye movement (REM) frequency, and electromyographic (EMG) and electrooculogram amplitude (EOG). On the basis of these indicators different behavioral states such as waking (W), waking in the presence

---

\* An invited contribution to the memorial issue of *Arch. Ital. Biol.* in honor of Professor Giuseppe Moruzzi, who first suggested a dynamic functional relationship between brain state and plasticity (37).

of theta hippocampal rhythm (W theta), sleep with synchronized EEG (S), and sleep with desynchronized EEG (D or REM sleep), can be defined (Table 1).

Table 1. - Relationships between different behavioral states with external arousal, electroencephalographic voltage (EEG), rapid eye movement (REM) frequency, electromyographic amplitude (EMG), electrooculogram amplitude (EOG), and neuronal activity in locus coeruleus (LC) and gigantocellular tegmental field (FTG).

	Behavioral State			
	W	W theta	S	REM
External Arousal	+++	++++	+	-
EEG	+	?	-	+
EMG	++	-	+	-
EOG	++	?	-	+++
LC	+++	++++	++	+
FTG	+	++++	++	+++

W: waking; W theta: waking in the presence of hippocampal theta rhythm; S: sleep with synchronized EEG; REM: sleep with desynchronized EEG.

Table 1 shows the relationships between different behavioral states and their indicators. External arousal decreases monotonically from waking state to REM sleep; new information is readily acquired in waking because the animal is easily aroused. Cortical EEG increases during W and REM states. Motor activity reflected by EMG is increased during W, attenuated during S, and clearly decreased in both W theta (55) and REM sleep. EOG recordings indicate eye movements during waking and REM states.

McCarley and Hobson (29) proposed a reciprocal interaction model for sleep cycle oscillation that has recently been revised by Hobson *et al.* (21). During waking paramedian pontine reticular formation or gigantocellular tegmental field (FTG) cells rarely discharge because they are inhibited by locus coeruleus (LC) and raphe nucleus (RN) cells. For simplicity, in the present paper we restrict our attention to the LC. LC inhibition decreases and FTG activity increases throughout synchronized sleep. The mechanism for decreasing LC activity is unknown but may be compounded of an early disfacilitation (by the circadian clock) and a later inhibition (from recurrent collaterals or interneurons). As FTG activity increases in desynchronized sleep, more activity is elicited in the LC, whose inhibitory influence on the FTG ends REM sleep.

Both FTG activity (56-58) and LC activity increase with hippocampal theta (42). Table 1 shows the relationship between behavioral states and two areas in the brain that have been proposed to control them, namely LC and FTG cells. There appears to be a tight link between the activation of brainstem FTG and LC neurons and the hippocampal theta generator network. This link, in turn, suggests a functional role in attention and information selection.



## THE ROLE OF HIPPOCAMPUS AND NORADRENERGIC SYSTEM IN ATTENTIONAL PROCESSES.

Flicker *et al.* (16) suggested that learning phenomena at the cellular level are under the control of noradrenergic (NA) and serotonergic (5HT) systems. Both the NA system and the hippocampus seem to be involved in the regulation of learning through the control of attentional processes.

Grastyan *et al.* (17) were among the first to implicate the hippocampus in attentional processes. They proposed that the hippocampus inhibits the orienting response (OR) to non-significant conditioned stimulus (CSs).

Douglas and Pribram (15) proposed that the hippocampus excludes CSs from attention through efferent control of sensory reception. This control inhibits the reception of CSs that have been associated with nonreinforcement. In a related view, Kimble (24) proposed that the hippocampus enables the organism to uncouple its attention from one CS and shift its attention to new and more consequential environmental events. Douglas (14) proposed yet another version of the Douglas and Pribram theory in which the hippocampus correlates a CS with non-reinforcement, thereby reducing its attentional priority. These three models share the postulate that the hippocampus is the organ of internal inhibition, and they all relate internal inhibition to an attentional mechanism.

Pribram and Isaacson (40) suggested that the hippocampus computes the probability that some behavior will proceed to its completion. If this probability is high, the animal does not alter its behavior. If it is low, e.g., because some novelty has been detected, a behavioral shift involving attentional and response changes is produced.

Solomon and Moore (51; cf. also 49, 50) hypothesized that the hippocampus participates in the "tuning out" of CSs poorly associated with reinforcement. This view is closely related to that of Douglas (14), but whereas for Douglas the hippocampus attenuates the reception of a nonreinforced CS, for Solomon and Moore (51) it attenuates the reception of CSs that are irrelevant to the task at hand. Moore (34) proposed a neural model to explain how the hippocampus participates in "tuning out" during conditioning of the rabbit's nictitating membrane (NM) response.

Attentional theories of learning (28, 38) propose that rate of learning about a given stimulus is controlled by the attention devoted to that particular stimulus.

Mackintosh's (28) attentional theory of conditioning can be represented by an equation describing the variation ( $\Delta$ ) of the associate value ( $V$ ) between CS and the unconditioned stimulus (US) :  $\Delta V = \theta \alpha (\lambda - V)$ , where  $\theta$  is a constant ( $0 \leq \theta \leq 1$ ),  $\alpha$  is the attentional factor representing the CS's associability ( $0 \leq \alpha \leq 1$ ), and  $\lambda$  is the intensity of the US.  $V$  can be interpreted as the prediction of the US by CS. According to Mackintosh (28),  $\alpha$  represents the relevancy of a given stimulus in a given task.  $\alpha$  for a given stimulus increases whenever the outcome of a trial is predicted better by that stimulus than by any other stimuli on that trial. Otherwise  $\alpha$  decreases.

Moore and Stickney (35) gave precise quantitative expressions to Mackintosh's

rules for changing  $\alpha_i$ : Whenever the outcome of a trial is predicted better by a stimulus, A, than by any other stimulus present with A,  $\alpha_A$  is increased by  $\Delta\alpha_A = C (1 - \alpha_A) (V_A - V_B)$ , where  $V_A$  is the associative value of stimulus A and  $V_B$  is the second highest associative value from the set of stimuli presented with A. Otherwise,  $\alpha_A$  is decreased by  $\Delta\alpha_A = c (0 - \alpha_A) (V_B - V_A)$ , where  $V_B$  is the highest associative value from the set of stimuli presented with A. Moore and Stickney (M-S) (35) proposed a model of the hippocampal function based on Mackintosh's (28) attentional theory. In its simplest form, the M-S theory assumes that hippocampal lesions (HL) prevent  $\alpha$  from decreasing. A recent version of the model, designated the M-S-S model, has been presented (44). The M-S-S model describes HL effects in classical conditioning paradigms, such as acquisition, extinction, conditioned inhibition, latent inhibition, blocking, and overshadowing.

Mason and Iversen (33) proposed that the NA system facilitates attentional processes, mainly by filtering out irrelevant stimuli. This view of the function of the NA system is closely related to Solomon and Moore's (51) hypothesis that the hippocampus participates in the "tuning out" of CSs poorly associated with reinforcement. Mason and Iversen's theory (33) can explain many attentional effects of lesions of the dorsal noradrenergic bundle (DNB) and the pontine nucleus locus coeruleus (LC) in the same paradigms explained by the M-S-S model.

#### LEARNING, ATTENTION, AND HIPPOCAMPAL THETA STRENGTH

Kaye and Pearce (23) report that the strength of the OR during acquisition of classical conditioning is proportional to the novelty of event  $k$  given by  $|\lambda^k - \sum_j V_j^k|$ , where  $\lambda^k$  represents the intensity of event  $k$ , and  $\sum_j V_j^k$  the prediction of event  $k$  made upon all stimuli present. Novelty,  $|\lambda^k - \sum_j V_j^k|$  increases with increasing uncertainty about event  $k$ , and decreases when the uncertainty is reduced through learning. Such a relationship between learning and the OR is supported by Thompson and Shaw's (54) data, showing that evoked potential of cortical association neurons is inversely related to the OR.

According to Anchel and Lindsley (1) hippocampal theta rhythm is correlated with the strength of the OR. Therefore, hippocampal theta activity and OR would be associated to large values of novelty, whereas non-theta activity and absence of OR would be associated with small values of novelty.

The relationships between behavioral state and hippocampal theta and behavior are shown in Table 2.

Eye, head, and body movements involved in the OR towards a stimulus seem to be under the control of the superior colliculi and must involve the FTG which contains premotor neurons for the eye, neck, and trunk (see 10). Stevens and Foreman (53) proposed that the hippocampus would control collicular activity, through a hippocampal-cingulate cortex pathway to the colliculi. It is conceivable, therefore, that eye movements in both wake and sleep are under the control of the hippocampus, and correlated to hippocampal theta activity. The REMs that occur during sleep would be expressions of OR associated with increased FTG activity.



Table 2. - Relationships between different behavioral states with hippocampal theta activity, orienting responses (OR), and neuronal activity in locus coeruleus (LC) and gigantocellular tegmental field (FTG).

	Behavioral State			
	W	W theta	S	REM
Hippocampal theta	-	+	-	+
Orienting Response	-	+	-	PGO?
LC	+++	++++	++	+
FTG	+	++++	++	+++

W: waking; W theta: waking in the presence of hippocampal theta rhythm; S: sleep with synchronized EEG; REM: sleep with desynchronized EEG. PGO: pontogeniculooccipital waves

#### EFFECTS OF HIPPOCAMPAL AND NORADRENERGIC SYSTEM LESIONS ON CLASSICAL CONDITIONING

In this section we show that many of the effects of hippocampal lesions (HL) are also obtained by lesions of the LC and the NA system. In addition to changes in learning paradigms involving attentional processes that are presented here, HL and lesions of the NA system share a large number of common effects (see ref. 18, pag. 348).

*Extinction.* Extinction of conditioned NM response in rabbits appears to be unaffected by HL (4, 45). However, HL rabbits have been reported to show greater resistance to extinction than normals following reacquisition (45). Lesions of the LC increased resistance to extinction of classical conditioning in the rabbit (30).

*Conditioned inhibition.* Solomon (49) found that conditioned inhibition of the rabbit NM response was not affected by HL. Lorden *et al.* (26) did not observe deficits in conditioned inhibition in NA-depleted animals.

*Latent inhibition.* Latent inhibition (LI) refers to the finding that repeated presentations of the CS alone (before pairing it with the US) produces retardation in the acquisition of the CR. Animals with HL are reported to show impaired LI (32, 51). Depletion of NA also produced impairments in latent inhibition (26).

*Blocking.* In blocking, an animal is first conditioned to a CS (A). This training is followed by conditioning to a compound CS consisting of A and a second stimulus (B). This procedure results in weaker conditioning to B, as a component of the compound CS, than would occur without the prior conditioning to Solomon (49) found that HL disrupted blocking of the rabbit NM response, and Rickert *et al.* (43) reported similar effects of HL on conditioned suppression in rats. Lorden *et al.* (27) observed also deficits in blocking in NA depleted animals.

*Reversal of differential conditioning.* Berger and Orr (4) contrasted HL and control rabbits in two-tone differential conditioning and reversal of the rabbit NM response. Although HL did not affect initial differential conditioning, these animals were incapable of suppressing CRs to the original CS+ after it assumed

the role of CS-, even following extended training. Mason and Iversen (33) found that NA depletion produced deficits in reversal of discrimination.

*Sensory preconditioning.* Port and Patterson (39) reported disruption of sensory preconditioning of the NM response in rabbits with fimbrial lesions. The models considered in this report can be applied to sensory preconditioning only with additional assumptions that are discussed below. Recently, Archer *et al.* (2) reported that NA depletion attenuated sensory preconditioning in rats.

The fact that many of the effects of HL in classical conditioning are also obtained by lesions of the NA system suggests that the action of the LC on the hippocampus modulates the computation of  $\alpha$ , at least when aversive unconditioned stimuli are used (see ref. 22). Another factor controlling hippocampal processing is the septal input conveying information coming from the FTG, about the degree of uncertainty on a given event. The raphe nuclei also contribute to the modulation of hippocampal activity. In the absence of NA modulation, attention is devoted to every CS independently of the prediction made by the other CSs, and therefore more is learned about irrelevant CSs.

#### HIPPOCAMPAL INFORMATION PROCESSING

As mentioned above, according to the M-S-S attentional theory the hippocampus is involved in the computation of  $\alpha$ . In this section we examine what information is represented in the hippocampus, and how this information is processed in different hippocampal areas.

Berger *et al.* (5) found that CA1 and CA3 pyramidal cells increased their frequency of firing over conditioning trials with a pattern that correlates with the amplitude-time course of the rabbit NM response.

In addition to CA1 and CA3 pyramidal cells, activity from other cell types has been recorded from the hippocampus during NM conditioning. For instance, Weisz *et al.* (59) found that granule cells in the dentate gyrus exhibited a stimulus-evoked theta firing when rabbits were trained with a CS followed by a US, but not when they were trained with CS and US unpaired presentations. According to Anchel and Lindsley (1) hippocampal theta rhythm is correlated with the strength of the OR. It was indicated before that the novelty of event  $k$ ,  $|\lambda^k - \sum_j V_j^k|$ , is correlated with the strength of the OR. Consequently, activity of granule cells might be described by novelty  $|\lambda^k - \sum_j V_j^k|$ .

Evidence has accumulated that some cells, other than the granule cells, would compare actual and predicted events, i.e.,  $|\lambda^k - \sum_j V_j^k|$ . For instance, Segal and Olds (48) and Segal *et al.* (47) showed that cells in the CA1 and dentate regions increased firing rate to a tone CS that preceded food US. When the tone CS was changed to precede an aversive US, the CA1 neurons continued to exhibit an increased firing rate, but dentate cells decreased their firing rate. Specific cells in the dentate seem to be responsive to changes in the CS meaning. Consistent with these results, Deadwyler *et al.* (13) found that evoked potentials recorded from



the dentate gyrus were associated with unexpected stimulus changes. Ranck (41) found cells in CA1 ("approach-consummate-mismatch" cells) that are most active when an expected US is not presented, and cells in CA3 ("approach-consummate" cells) that are most active before and during consummatory behaviors. Berger and Thompson (6) noted that in the type of experiments cited above, hippocampal cells first signalled a CS, or a place predicting a given CS, and afterwards signalled its absence. This pattern of firing is well described by  $|\lambda^k - \sum_j V_j^k|$ , where  $\sum_j V_j^k$  increases with the temporal or the spatial proximity of the rewarded CS. In the absence of the US, at the point where the temporal trace reaches its maximum or the CS is approached, the difference  $|0 - \sum_j V_j^k|$  reaches a maximum value.

Some evidence suggests that the activity of some hippocampal cells is correlated with the associability value. For example, Best and Best (8) report that tone presentation increased CA1 activity after tone-US pairings in rats not preexposed to the tone (large associability) but not in rats receiving tone preexposure in a latent inhibition paradigm (small associability).

Berger and Thompson (7) recorded neuronal unit activity from the medial septum during classic conditioning of the rabbit NM. They found that medial septal responses tend to decrease with repeated CS presentations in both paired conditioning and unpaired control groups. They suggested that neural activity in medial septum represents an arousal signal that controls hippocampal theta. This medial septal arousal signal is a precursor of the increased hippocampal unit activity during acquisition of classical conditioning. As in the case of granule cells, medial septal activity might be correlated with the value of associability.

Berger and Thompson (6) proposed that the long-term potentiation (LTP) effect would provide a possible mechanism for the sustained increased hippocampal unit activity during acquisition of classical conditioning. According to Schmajuk and Moore (44) the hippocampus computes and stores the value of the associability for every event. It is possible that LTP provides the mechanism for storing associability values. It has been recently reported that the optimal frequency for obtaining hippocampal LTP is theta frequency (25).

#### LC MODULATION OF HIPPOCAMPAL INFORMATION PROCESSING: A NEW PARAMETER IN THE ATTENTIONAL MODEL

As mentioned above, many of the effects of hippocampal lesions HL are also obtained by lesions of LC and DNB, suggesting that control of neural plasticity is under the control of LC and mediated through the modulation of the hippocampal formation (but also see 31).

The hippocampus receives important input from the locus coeruleus. Segal and Bloom (46) found that LC stimulation augments inhibitory response in hippocampal unit activity to non-significant stimulus and augments excitatory response to a significant tone, suggesting that hippocampal attentional involvement is under

the modulation of the NA system. In this sense, as Aston-Jones *et al.* (3) suggested, NA action in the hippocampus would help to "filter out" irrelevant information.

Winson (60) suggested that different neural gates in the hippocampal trisynaptic circuit would allow or impede flow of information according to the animal's behavioral state. Flow of information through the hippocampal circuit would be under the control of NA and serotonin. During waking information flow from the entorhinal cortex to CA1 is restricted, whereas in the S sleep state it is facilitated. Flow of information through the dentate and CA3 increases with increased FTG and theta activity.

On the basis of the data presented above, the hippocampal contribution to learning would be highly state-dependent, as follows: In waking, noradrenergic input would modulate hippocampal neurons so that selective filtering and tuning out could occur; in REM sleep the noradrenergic deafferentation would result in the loss of selectivity and tuning out.

We propose a formal model for the effect of the LC modulation on hippocampal activity, by assuming that the term  $c$ , in the M-S-S equations defining  $\alpha$ , depends on the level of LC activity. The strength of term  $c$  would be estimated by the LC activity level which is state-dependent. The rate of change in  $\alpha$  is under the control of LC activity ( $\Delta\alpha_A = c(1 - \alpha_A)(V_A - V_B)$  and  $\Delta\alpha_A = c(0 - \alpha_A)(V_B - V_A)$ ), and therefore, in the absence of LC activity, the hippocampus is not capable of learning about the relevancy of different stimuli. Note that whereas in the Moore and Stickney (35) model HL prevents  $\alpha$  only from decreasing, in the present paper we assume that absence of LC activity prevents  $\alpha$  either from decreasing or increasing.

#### THE HIPPOCAMPAL FORMATION, LC, AND SLEEP AND PLASTIC PROCESSES

This section attempts an integration of the functions of LC, FTG, and hippocampus during sleep and learning. It is apparent from Table 2 that whereas the FTG is active during both waking theta and sleep, generating hippocampal theta activity and OR during waking and hippocampal theta activity and PGO during sleep, the LC is differentially active during learning and sleep, controlling the non-redundancy of the information stored in memory.

Aston-Jones *et al.* (3) suggested that LC cells "may be primarily influenced by two distinct input systems: excitatory afferents reflecting salient external stimuli, and inhibitory afferents which reflect internally generated signals concerning tonic vegetative requirements". Sleep onset might be determined by the interaction between the vegetative inhibitory input and the external excitatory novelty  $|\lambda^k - \sum_j V_j^k|$  signals, and a decrease in  $|\lambda^k - \sum_j V_j^k|$  may facilitate vegetative sleep requirements. In this sense, sleep onset is seen as correlated with and perhaps identical to physiological habituation.

As indicated above, during waking the presence of theta is proportional to the difference  $|\lambda^k - \sum_j V_j^k|$ , where  $\lambda^k$ , representing external stimuli, is greater



than 0. Learning occurs until  $\lambda^k = \sum_j V_j^k$ . During sleep, theta might be proportional to  $|0 - \sum_j V_j^k|$ , that is, to predictions that are not matched by external events. The fact that cortical lesions affect the REMs suggests that these internally generated stimuli could activate memory sites and retrieve associated stimuli. We cannot resist speculation that this physiological process of novelty and dishabituation is related to the common experience of surprise and anxiety during dreaming. The cognitive defects of that state (such as disorientation and loss of self-observational awareness) are also possible correlates of the enhanced novelty signal that we have modeled.

Bloch *et al.* (9) found that REM sleep increases after either positively or negatively reinforced learning tasks in rats, that is, when  $\sum_j V_j^k$  has increased after learning. During REM sleep, Steriade *et al.* (52) found increased firing rates of cortical association neurons, a result that suggests that information is being processed in the association cortex.

If no external information is received during sleep, and the the brain is not extinguishing associations acquired during waking, it is possible that the brain is strengthening those associations that acquired associative values in reason of their relevancy. Notice that, according to the McCarley and Hobson (29) model, as FTG and hippocampal theta activities increase during REM sleep, more activity is elicited in the LC, whose inhibitory influence on the FTG ends REM sleep.

#### THE RECIPROCAL INTERACTION MODEL AND THE CONTROL OF SLEEP AND LEARNING

Figure 1 shows a possible integration of the McCarley and Hobson (30) reciprocal interaction model for sleep cycle oscillation and an attentional model for hippocampal function (44).

The reciprocal inhibition between FTG and LC activity proposed by the McCarley and Hobson (29) model may affect the information processing carried out in the hippocampus during different behavioral states. In a predictable situation during waking, FTG cells rarely discharge because no novelty is detected, and LC neurons are moderately active. If the predictable situation lasts,  $|\lambda^k - \sum_j V_j^k|$  tends to zero, LC cells also decrease their activity, and a sleep period might start.

If the environment becomes unpredictable during waking,  $|\lambda^k - \sum_j V_j^k| > 0$ , FTG cells increase their activity proportionally to the level of uncertainty about the situation, hippocampal theta rhythm appears, and ORs are elicited. In addition, the LC is activated and its activity modulates the hippocampal computation of the relevancy of the received information. This modulation can be described as the rate of change,  $c$ , in the attentional parameter  $a$ :  $\Delta\alpha_A = c(1 - \alpha_A)(V_A - V_B)$  and  $\Delta\alpha_B = c(0 - \alpha_B)(V_B - V_A)$ .  $\alpha_A$  controls the rate of learning in cortical and subcortical areas of the brain.

At sleep onset, LC inhibition decreases and FTG activity increases, leading to S sleep. As FTG activity increases, REM sleep starts. Since during sleep the threshold for external stimuli is high, brain activity increases proportionally to the internally

generated novelty, more activity is elicited in the LC, which inhibitory influence on the FTG ends REM sleep.

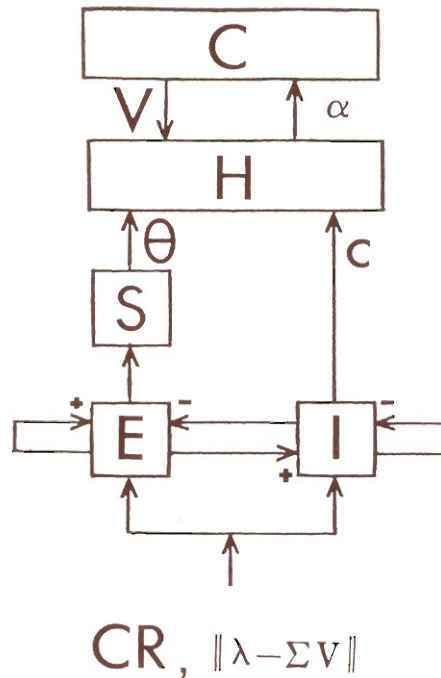

Fig. 1. — *A possible integration of the reciprocal interaction model for sleep cycle oscillation (McCarley and Hobson, ref. 29) and the attentional model for hippocampal function (Schmajuk and Moore, ref. 44). C: cortex; H: hippocampal area; V: associations;  $\alpha$ : associability;  $\theta$ : theta rhythm; c: rate of change of  $\alpha$ ; S: medial septum; E: excitatory areas (On-REM) for REM sleep (gigantocellular tegmental field (FTG), pontogeniculoccipital (PGO) bursts, oculomotor areas); I: inhibitory areas (Off-REM) for REM sleep (locus coeruleus, raphe nuclei);  $\|\lambda - \Sigma V\|$ : novelty; CR: circadian rhythm.*

#### INTERNALLY GENERATED “PLACE” STIMULI: THE PGO SYSTEM

In addition to the decreases in external sensory input and in the aminergic modulation that distinguish the hippocampal activation of REM sleep from that of waking, there is a dramatic increase in internally generated signals, the PGO waves. We consider it highly significant that these waves behave quite differently in waking and REM sleep. During the wake state individual waves may be triggered by novel stimuli; but in that state the individual waves rapidly habituate (i.e., repeated stimuli fail to elicit waves) and clusters of waves are never seen. This has led Morrison (36) to propose that PGO waves reflect the activation of a “startle” network. We accept this concept and emphasize its functional equivalence to novel stimulus detection and the OR. During REM sleep, the PGO waves evolve spontaneously, first as single, high amplitude waves (identical in form to the OR



in waking) and later as one-second long clusters of 4-8 waves of decrementing amplitude.

The PGO wave clusters of REM sleep are correlated both temporally and directionally with the rapid eye movements. In addition, there is a strong tendency for synchronization of hippocampal theta during the PGO wave clusters; it is significant that both have the same intrinsic frequency range (4-8 c/s). The hippocampal system might thus be linked to eye movements during both REM sleep and waking. The hippocampal output might even be directing eye movements toward the places where a predicted CS is expected to be at a given moment. PGO waves recorded in lateral geniculate and occipital cortex have phase lags of hundreds of milliseconds in respect to FTG activity, suggesting its possible onset at the FTG, which activates hippocampal theta activity, which in turn controls the colliculi. Hobson (19) suggested that eye movements in the absence of reafferent signals generate stimulus "perceptions".

The implications of these findings are manifold: 1) It is clear, at least in REM sleep, that the hippocampus is not only tonically activated but that it receives strong internally generated phasic signals from the brainstem. 2) These phasic signals convey directionally specific information regarding eye movement; hence they may have spatially significant orientation data. 3) It remains to be seen whether the hippocampus also receives such data as part of the startle/OR in waking. But whatever the answer to that question, the hippocampus must make quite different, but functionally related, use of the signals in the two states, because (4). The system is not receiving sensory data and is aminergically deafferented during REM sleep.

#### FUNCTIONAL IMPLICATIONS FOR DISORDERS OF MEMORY IN DREAM AND DISEASE STATES.

The McCarley-Hobson model (29) and its recent revisions by Hobson *et al.* (21) accounts for the change in excitability of the PGO network from inhibited (in waking) to disinhibited (in REM sleep) in terms of withdrawal of both serotonergic and noradrenergic damping of the cholinceptive and probably cholinergic PGO burst cells of the peribrachial region of the pons. As a consequence of these changes it is reasonable to predict that the hippocampus, like the cerebral cortex, undergoes a marked shift in neurotransmitter ratio, from predominantly aminergic (in waking) to predominantly cholinergic (in REM sleep) with pulsatile increases in the ratio difference when the PGO waves are generated. In view of the known defects of cholinergic and amine neurotransmitter systems in human learning and memory disorders, these considerations take on considerable clinical as well as basic scientific importance.

The normal cognitive correlates of the REM sleep state, our dreams, also warrant further consideration in light of our hypotheses. A recent quantitative assessment of the dream feature called bizarreness has revealed that spatial disorientation is a major contributing factor (20). We propose that phasic activation of the

hippocampus by internally generated place stimuli, the PGO waves, may contribute to this distinctive dream feature.

Integral aspects of REM sleep that may enhance long-term storage of learned information include: hippocampal theta (possibly mediated by FTG firing); and PGO waves which convey (at least) spatially specific signals to the forebrain and possibly the hippocampus. Orientational data, including place maps, may thus be reinforced and/or reorganized during each REM sleep period. We acknowledge the formal relationship of this aspect of the theory presented here to the "REM sleep and forgetting" hypothesis of Crick and Mitchison (11), and the "memory consolidation" hypothesis of Davis (12). More empirical data is necessary to determine the degree to which either - or both - of these processes is enhanced by REM sleep.

#### CONCLUSIONS

Flicker *et al.* (16) suggested that the LC participates in both the control of sleep-state and learning processes. Supporting this idea, the present paper shows how learning about the relevancy ( $\alpha$ ) of different stimuli depends on the level of LC activation. Although the scope of the present paper is limited to the control of computation of  $\alpha$  by the LC, this is not the only type of learning that seems to be under noradrenergic control. As mentioned above, association between two CSs in a sensory preconditioning paradigm is also affected by LC lesions.

One virtue of the conjoint model we propose in the present paper is its testability. Since REM sleep can now be experimentally enhanced or suppressed (21), the state variable is manipulable. In this way each of the inputs to the hippocampus could be selectively controlled to test their effects on hippocampal physiology and learning capability.

#### SUMMARY

The present paper relates the reciprocal interaction model for sleep cycle oscillation (McCarley and Hobson, ref. 29) to an attentional model of hippocampal function (Schmajuk and Moore, ref. 44). We consider mechanisms by which the interaction between gigantocellular tegmental field (FTG) cells and locus coeruleus (LC) activity proposed by the sleep cycle model may differentially modulate the information processing carried out in the hippocampus as described by the attentional model. Our fundamental assumption is that learning about the relevancy of different stimuli is proportional to the level of LC activation.

If the environment becomes unpredictable during waking, the FTG and LC are activated and the LC facilitates hippocampal learning about stimulus relevancy. In a predictable situation during waking, FTG cells discharge rarely because no novelty is detected, and LC neurons are moderately active. If the predictable situa-



tion lasts, LC cells also decrease their activity, and a sleep period might start. At sleep onset, LC inhibition decreases and FTG activity is low leading to slow sleep. As FTG activity increases and LC activity reaches its low point, REM sleep starts. Because LC activity is low during REM sleep, values of stimulus relevancy remain unchanged. Since during sleep the threshold for external stimuli is high, only internally generated novel stimuli (subjectively perceived as dream mentation) may activate the LC. LC renewed inhibitory influence on the FTG ends REM sleep.

*Acknowledgments.* — This paper was supported in part by NIH grant MH-13923 to the first author. The second author was supported by NSF Grant IST8417756, while at the Center for Adaptive Systems, Boston University, Boston, MA, 02215, USA.

## REFERENCES

1. ANCHEL, H. and LINDSLEY, D. B. Differentiation of two reticulo-hypothalamic systems regulating hippocampal theta. *Electroenceph. Clin. Neurophysiol.*, **32**: 209-226, 1975.
2. ARCHER, T., COTIC, T. and JARBE, T. U. C. Noradrenaline and sensory preconditioning in the rat. *Behav. Neurosci.*, **100**: 704-711, 1986.
3. ASTON-JONES, G., FOOTE, S. L. and BLOOM, F. E. Anatomy and physiology of locus coeruleus neurons: Functional implications. Pp. 92-116. In: ZIEGLER, M. G. and LAKE, C. R. (Eds), *Norepinephrine: Clinical Aspects*. Vol. 2, Baltimore, MA, Williams and Wilkins, 1984.
4. BERGER, T. W. and ORR, W. B. Hippocampectomy selectively disrupts discrimination reversal conditioning of the rabbit nictitating membrane response. *Behav. Brain Res.*, **8**: 49-68, 1983.
5. BERGER, T. W., RINALDI, P. C., WEISZ, D. J. and THOMPSON, R. F. Single-unit analysis of different hippocampal cell types during classical conditioning of rabbit nictitating membrane response. *J. Neurophysiol.*, **50**: 1197-1219, 1983.
6. BERGER, T. W. and THOMPSON, R. F. Neuronal plasticity in the limbic system during classical conditioning of the rabbit nictitating membrane response. I. The hippocampus. *Brain Res.*, **145**: 323-346, 1978.
7. BERGER, T. W. and THOMPSON, R. F. Neuronal plasticity in the limbic system during classical conditioning of the rabbit nictitating membrane response. II. Septum and mammillary bodies. *Brain Res.*, **156**: 293-314, 1978.
8. BEST, M. R. and BEST, P. J.. The effects of state of consciousness and latent inhibition on hippocampal unit activity in the rat during conditioning. *Exp. Neurol.*, **51**: 564-573, 1976.
9. BLOCH, V., HENNEVIN, E. and LECONTE, P. Relationship between paradoxical sleep and memory processes. Pp. 329-343. In: BRAZIER, M. A. B., (Ed.), *Brain Mechanisms in Memory and Learning: From the Single Neuron to Man*, New York, Raven Press, 1979.
10. CHALUPA, L. M. Visual physiology of the mammalian superior colliculus. Pp. 775-818. In: VANEGAS, H. (Ed.), *Comparative Neurology of the Optic Tectum*. New York, Plenum, 1984.
11. CRICK, F. and MITCHISON, G. The function of dream sleep. *Nature*, **304**: 111-114, 1983.
12. DAVIS, B. Sleep and the maintenance of memory. *Perspect. Biol. Med.*, **28**: 457-464, 1985.
13. DEADWYLER, S. A., WEST, M. O. and ROBINSON, J. H. Entorhinal and septal inputs differentially control sensory-evoked responses in the rat dentate gyrus. *Science*, **211**: 1181-1183, 1981.

14. DOUGLAS, R. Pavlovian conditioning and the brain. Pp. 529-553. In: BOEAKES, R. A. and HALLIDAY, M. S. (Eds.). *Inhibition and Learning*. London, Academic Press, 1972.
15. DOUGLAS, R. and PRIBRAM, K. H. Learning and limbic lesions. *Neuropsychologia*, **4**: 197-220, 1966.
16. FLICKER, C., MCCARLEY, R. W. and HOBSON, J. A. Aminergic neurons: State control and plasticity in three model systems. *Cell. Molec. Neurobiol.*, **1**: 123-166, 1981.
17. GRASYAN, E., LISSAK, K., MADARAZ, I. and DONHOFFER, H. Hippocampal electrical activity during the development of conditioned reflexes. *Electroenceph. Clinical Neurophysiol.* **11**: 409-430, 1959.
18. GRAY, J. A. *The Neuropsychology of Anxiety: An Enquiry into the Functions of the Septo-hippocampal System*. Oxford, Clarendon, 1982.
19. HOBSON, J. A. Sleep mechanisms and pathophysiology: Some clinical implications of the reciprocal interaction hypothesis of sleep control. *Psychosomatic Med.*, **45**: 123-140, 1983.
20. HOBSON, J. A., HOFFMAN, S. A., HELFAND, R. and KOSTNER, D. Dream bizarreness and the activation-synthesis hypothesis. *Human Neurobiol.*, **6**: 157-164, 1987.
21. HOBSON, J. A., LYDIC, R. and BAGHDOYAN, H. A. Evolving concepts of sleep cycle generation: From brain centers to neuronal populations. *Behav. Brain Sci.*, **9**: 371-448, 1986.
22. JACOBS, B. L. Single unit activity of locus coeruleus neurons in behaving animals. *Progr. Neurobiol.*, **27**: 183-194, 1986.
23. KAYE, H. and PEARCE, J. M. The strength of the orienting response during Pavlovian conditioning. *J. Exp. Psychol., Animal Behavior Processes*, **10**: 90-109, 1984.
24. KIMBLE, D. P. Hippocampus and internal inhibition. *Psychol. Bull.*, **70**: 285-295, 1968.
25. LARSON, J., WONG, D. and LYNCH, G. Pattern stimulation at the theta frequency is optimal for the induction of hippocampal long-term potentiation. *Brain Res.*, **368**: 347-350, 1986.
26. LORDEN, J. F., RICKERT, E. J. and BERRY, D. W. Forebrain monoamines and associative learning: I. Latent inhibition and conditioned inhibition. *Behav. Brain Res.*, **9**: 181-199, 1983.
27. LORDEN, J. F., RICKERT, E. J. and BERRY, D. W. Forebrain monoamines and associative learning: II. Superconditioning/Unblocking. *Behav. Brain Res.*, **9**: 201-211, 1983.
28. MACKINTOSH, N. J. A theory of attention: Variations in the associability of stimuli with reinforcer. *Psychol. Rev.*, **82**: 276-298, 1975.
29. MCCARLEY, R. W. and HOBSON, J. A. Neuronal excitability modulation over the sleep cycle: A structural and mathematical model. *Science*, **189**: 58-60, 1975.
30. MCCORMICK, D. A. and THOMPSON, R. F. Locus coeruleus lesions and resistance to extinction of a classically conditioned response: Involvement of the neocortex and hippocampus. *Brain Res.*, **245**: 239-249, 1982.
31. McELIGOTT, J. G., EBNER, T. J. and BLOEDEL, R. J. Reduction of cerebellar norepinephrine alters climbing fiber enhancement of mossy fiber input to the Purkinje cell. *Brain Res.*, **397**: 245-252, 1986.
32. MACFARLAND, D. J., KOSTAS, J. and DREW, W. G. Dorsal hippocampal lesions: Effects of preconditioning CS preexposure on flavor aversion. *Behav. Biol.*, **2**: 398-404, 1978.
33. MASON, S. T. and IVERSEN, S. D. Theories of the dorsal bundle extinction effect. *Brain Res. Rev.*, **1**: 107-137, 1979.
34. MOORE, J. W. Brain processes and conditioning. Pp. 111-142. In: DICKINSON, A., BOAKES, R. A., (Eds.), *Mechanisms of Learning and Behavior*. Hillsdale, Lawrence Erlbaum, 1979.
35. MOORE, J. W. and STICKNEY, K. J. Formation of attentional-associative networks in real time: Role of the hippocampus and implications for conditioning. *Physiol. Psychol.*, **8**: 207-217, 1980.



36. MORRISON, A. R. Brainstem regulation of behavior during REM sleep and wakefulness. *Progr. Neurobiol. Physiol. Psychol.*, **8**: 91-131, 1979.
37. MORUZZI, G. The functional significance of sleep with particular regard to the brain mechanism underlying consciousness. Pp. 345-388. In: ECCLES, J. C. (Ed.). *Brain and Conscious Experience*. New York, Springer-Verlag, 1966.
38. PEARCE, J. M. and HALL, G. A model for Pavlovian learning: Variations in the effectiveness of conditioned but not of unconditioned stimuli. *Psychol. Rev.*, **87**: 532-552, 1980.
39. PORT, R. L. and PATERSON, M. M. Fimbrial lesions and sensory preconditioning. *Behav. Neurosci.*, **98**: 584-589, 1984.
40. PRIBRAM, K. H., and ISAACSON, R. L. Summary. Pp. 429-441. ISAACSON R. L. and PRIBRAM, K. H. (Eds.). *The Hippocampus*. New York, Plenum Press, 1975.
41. RANCK, J. B., JR. Studies on single neurons in dorsal hippocampal formation and septum in unrestrained rats. *Exp. Neurol.*, **41**: 461-555, 1973.
42. RASMUSSEN, K., MORILAK, D. A. and JACOBS, B. L. Single unit activity of Locus Coeruleus neurons in the freely moving cat. I. During naturalistic behaviors and in response to simple and complex stimuli. *Brain Res.*, **371**: 324-334, 1986.
43. RICKERT, E. J., BENNET, T. L., LANE, P. and FRENCH, J. Hippocampectomy and the attenuation of blocking. *Behav. Biol.*, **22**: 147-160, 1978.
44. SCHMAJUK, N. A. and MOORE, J. W. Real-time attentional models for classical conditioning and the hippocampus. *Physiol. Psychol.*, **13**: 278-290, 1985.
45. SCHMALTZ, L. W. and THEIOS, J. Acquisition and extinction of a classically conditioned response in hippocampectomized rabbits (*Oryctolagus cuniculus*). *J. Comp. Physiol. Psychol.*, **79**: 328-333, 1972.
46. SEGAL, M. and BLOOM, F. E. The action of norepinephrine in the rat hippocampus. IV. The effects of locus coeruleus stimulation on evoked hippocampal unit activity. *Brain Res.*, **107**: 513-525, 1976.
47. SEGAL, M., DISTERHOFT, J. F. and OLDS, J. Hippocampal unit activity during classical aversive and appetitive conditioning. *Science*, **173**: 680-690, 1972.
48. SEGAL, M. and OLDS, J. Behavior of units in hippocampal circuit of the rat during learning. *J. Neurophysiol.*, **35**: 680-690, 1972.
49. SOLOMON, P. R. Role of the hippocampus in blocking and conditioned inhibition of rabbit's nictitating membrane response. *J. Physiol. Psychol.*, **91**: 407-417, 1977.
50. SOLOMON, P. R. Temporal versus spatial information processing theories of the hippocampal function. *Psychol. Bull.*, **86**: 1272-1279, 1979.
51. SOLOMON, P. R. and MOORE, J. W. Latent inhibition and stimulus generalization of the classically conditioned nictitating membrane response in rabbits (*Oryctolagus cuniculus*) following dorsal hippocampal ablation. *J. Comp. Physiol. Psychol.*, **89**: 1192-1203, 1975.
52. STERIADE, M., KITSIKIS, A. and OAKSON, G. Selectively REM-related increased firing rates of cortical association interneurons during sleep: Possible implications for learning. Pp. 47-63. In: BRAZIER, M. A. B. (Ed.), *Brain Mechanisms in Memory and Learning: From the Single Neuron to Man*. New York, Raven Press, 1979.
53. STEVENS, N. and FOREMAN, R. Relationships between the superior colliculus and hippocampus: Neural and behavioral considerations. *Behav. Brain Sci.*, in press.
54. THOMPSON, R. F. and SHAW, J. A. Behavioral correlates of evoked activity recorded from association areas of the cerebral cortex. *J. Comp. Physiol. Psychol.*, **60**: 329-339, 1965.
55. VANDERWOLF, C. H. and ROBINSON, T. E. Reticulo-cortical activity and behavior: A critique of the arousal theory and a new synthesis. *Behav. Brain Sci.*, **4**: 459-514, 1982.
56. VERTES, R. P. Brain stem activation of the hippocampus: A role for the magnocellular reticular formation and the MFL. *Electroenceph. Clin. Neurophysiol.*, **50**: 48-58, 1980.
57. VERTES, R. P. Brainstem generation of the hippocampal EEG. *Progr. Neurobiol.*, **19**: 159-186, 1982.

58. VERTES, R. P. Brainstem modulation of the hippocampus. Pp. 41-75. In: ISAACSON, R. L. and PRIBRAM, K. H. (Eds.) *The Hippocampus*. Vol. 4, New York, Plenum Press, 1986.
59. WEISZ, D. J., CLARK, G. A. and THOMPSON, R. F. Increased responsivity of dentate granule cells during nictitating membrane response conditioning in rabbit. *Behav. Brain Res.*, **12**: 145-154, 1984.
60. WINSON, J. Behaviorally dependent neuronal gating in the hippocampus. Pp. 77-91. In: ISAACSON, R. L. and PRIBRAM, K. H. (Eds.), *The Hippocampus*. Vol. 4, New York, Plenum, 1986.