

## TOPOGRAPHICAL LOCALISATION IN THE PROJECTIONS FROM THE INFERIOR OLIVE TO THE PARAVERMAL CORTEX OF THE ANTERIOR LOBE AND PARAMEDIAN LOBULE IN THE CEREBELLUM OF THE CAT. A BRIEF REVIEW

D. M. ARMSTRONG

*Department of Physiology, School of Medical Sciences, University of Bristol, Bristol BS8 1TD, United Kingdom*

### INTRODUCTION

The purpose of this contribution is to review briefly our current knowledge of the pattern of spatial localisation existing in the cat in the projections from the inferior olivary nucleus to an important area of the cerebellar cortex namely the parts of the paravermal or intermediate region (see ref. 38, and 39) which lie within the anterior lobe and the paramedian lobule. These parts receive abundant spinal inputs mediated via several spino-olivocerebellar paths and the olive cells that act as relays on these paths also receive important descending inputs. In addition to these pathways terminating as climbing fibres inputs are also provided by mossy fibre paths that include various direct and indirect spinocerebellar paths and also descending pathways including cerebro-ponto-cerebellar projections. In view of these strong connections both with the spinal cord and with higher centres it is not surprising that much evidence exists to show that the paravermal cortex together with nucleus interpositus, its corresponding deep cerebellar nucleus, is essential for the smooth regulation of movements of the limbs (see for example refs. 1 and 22).

A degree of somatotopical localisation is evident within the paravermal cortex such that its parts present in the rostral lobules, lobules I to IV, of the anterior lobe and the caudal folia of the paramedian lobule are often referred to as a "hindlimb" region while its parts that lie between these two regions (i.e. lobule V of the anterior lobe and the rostral folia of the paramedian lobule) together comprise a "forelimb" region. This division is not however a strict one because hindlimb input reaches some of the forelimb cortex and vice versa; in addition, for completeness, a "trigeminal" region should also be recognized, centred on lobule VI, the simple lobule (43 and 44). In the present context, however, the forelimb-hindlimb notation is a useful shorthand (see later).

The organization of the olivocerebellar projections, including those to paravermal cortex, was a life-long interest of Alf Brodal and I hope, therefore, that my topic is a fitting subject for inclusion in the present volume. Particular emphasis is placed on the manner in which this understanding has been reached and on features of the localisation that are still debatable.

## HISTORICAL BACKGROUND AND A REMINISCENCE OF ALF BRODAL

Fifty years ago Alf Brodal (15) published a paper entitled "Experimentelle Untersuchungen über die olivocerebellare Lokalisation" which has the status of a neuroanatomical classic. In it he studied the projection from inferior olive to cerebellum by making differently placed lesions in the cerebellum of young cats and rabbits and subsequently defining the patterns of retrograde cell loss in the olive. This method (the modified Gudden method) provided a detailed picture of a topographical localisation within the projection to the cerebellar cortex which was not improved on for around 30 years. The localisation revealed was a remarkably sharp one in which different olivary subnuclei projected to different cerebellar lobules according to a general plan in which the more lateral portions of the cortical sheet received olivocerebellar afferents from the more rostral portions of the olivary nucleus.

Between 1968 and 1974 Robin Harvey, Renee Schild and I restudied some aspects of the localisation using a quite different technique - that of mapping with microelectrodes the antidromic responses evoked in olivary neurones by using electrical stimuli delivered to the cerebellar surface to excite the terminals of the olivocerebellar axons (10, 14). This work confirmed some aspects of Alf Brodal's schema of the olivocerebellar localisation but it also indicated that many if not all of the olivocerebellar axons, by then known to terminate as climbing fibres (see refs. 6 and 17 for references), underwent extensive branching within the deep cerebellar white matter. In particular this and related electrophysiological work (see also refs. 8, 9, 11, 12 and 26) demonstrated that substantial numbers of Purkinje cells in the paramedian lobule received climbing fibres which were branches of parent olivocerebellar axons which also gave branches to the paravermal part of the anterior lobe. This implied much axonal branching in the sagittal plane and it resulted overall in an arrangement in which restricted portions of the olivary complex projected to narrow longitudinal strips of cerebellar cortex that extended across many folia and therefore across several lobules. Such a picture accorded well with Voogd's (61, 62) longitudinal subdivision of the cerebellar cortex as proposed on the basis of anatomical studies of the cerebellar myeloarchitecture but could not be reconciled in all its details with the Gudden picture of an olivocerebellar localisation organized on a lobular basis.

While our work was in progress Robin Harvey and I attended a meeting of European neuroscientists held at an hotel in Sandefjord in Norway and here I first met Alf Brodal. Robin Harvey and I were anxious to discuss our findings with him and at the start of the meeting he was pointed out to me in the hotel foyer. With some trepidation I decided to approach him but as I came near he was spotted by and fell into conversation with another eminent neuroanatomist so that I hovered uncertainly within earshot. To my youthful indignation Alf's companion began to express doubts about the emergent evidence for widespread branching of olivocerebellar axons, basing his objection on its apparent conflict with the pattern of localisation revealed with the retrograde degeneration method.

Needless to say, I waited anxiously for Alf's reply which was entirely characteristic—this new evidence, he said, seemed good so far as he had seen it and the Gudden method had its limitations because whether a cell would react to axotomy to the point of death and disappearance might depend on how many of its terminal branches were injured by the cerebellar lesion. Moreover the pattern of connection in very young animals might be substantially revised during later development. At that point I interrupted with a naive enthusiasm and a rudeness I cringe now to think of and launched into an over-long exposition of our recent work. Fortunately Alf received me with a kindness that was as much a part of him as his open-mindedness. A stimulating discussion began and although it was soon interrupted by dinner it was renewed later in the meeting.

My subsequent meetings with Alf Brodal were surprisingly few given that we often corresponded and exchanged reprints and that we both made further studies of the olivocerebellar projection. I always felt, however, that he was a touchstone of neuroanatomical quality and in putting together anatomical papers I have routinely asked myself and my colleagues whether this evidence would convince Alf Brodal. Despite Alf's passing I see no reason in the future to abandon asking that question.

#### PROGRESS 1974-1980

In 1974 existing knowledge of the inferior olivary nucleus was discussed in a review which included an account of the olivocerebellar localisation as it then appeared to the author (6). As is often the way with such reviews this account was shortly to require major revisions because the remainder of the 1970s saw the publication of many new studies. Thus, for example, very important investigations were carried out by Voogd and his co-workers (34, 35) who used anterograde degeneration and orthograde axonal transport-autoradiographic techniques to map the localisation. In addition Alf Brodal returned to the problem and between 1975 and 1978, together with Walberg, Hoddevik and Kotchabhakdi, published a major series of papers in which the technique of retrograde axonal transport tracing was used with HRP as the tracer substance and the methods of Graham & Karnovsky (see refs. 16, 18, 19, 21, 36, 37, 41) or of Mesulam (65) employed to visualize the tracer material. These studies were shortly followed by the classic review of Brodal and Kawamura (17). In all these publications, but particularly in the last, the information yielded by the HRP retrograde transport technique was correlated in masterly fashion with the findings of other studies including not only the relevant earlier electrophysiological and anatomical work but also the orthograde studies of Voogd and his co-workers referred to above.

The consensus of evidence provided by all studies indicated that in the cat the olivocerebellar projection is in essence entirely crossed and that the inferior olive comprises a number of subregions each of which provides the climbing fibres

terminating in one or sometimes two longitudinally oriented strips or zones of cerebellar cortex. The strips in the paravermal cortex (and also in the vermis) vary in width from 0.5 to c. 1.5 mm and following the nomenclature introduced by Voogd (61, 62) and proceeding from the cerebellar midline laterally they were given by Brodal and Kawamura (17) as the A and B zones together making up the vermal cortex and the C<sub>1</sub>, C<sub>2</sub>, and C<sub>3</sub> zones collectively comprising the paravermal cortex. Of these latter three zones C<sub>1</sub> and C<sub>3</sub> are both subdivided in the sense that the rostral and caudal ends of each are innervated from the lateral portion of the rostral half of the dorsal accessory olive while the remainder is supplied from the medial portion of the rostral half of the dorsal accessory olive. These two subdivisions of the C<sub>1</sub> and C<sub>3</sub> zones are often referred to respectively as the "hindlimb" and "forelimb" parts of the zones (cfr. Introduction). In addition to the A, B and C zones D<sub>1</sub> and D<sub>2</sub> zones were recognised, together making up the hemispherical or lateral cortex.

Brodal and Kawamura (17) also took into consideration the many electrophysiological studies of localisation in the spino-olivocerebellar pathways (SOCPs). These investigations were carried out principally by Oscarsson and his co-workers (see for refs. 46, 48-50) and were highly relevant because they demonstrated the existence of a considerable number of such pathways each of which terminated in one or (usually) more longitudinal cortical zones that appeared each to correspond with one of the olivocerebellar projection zones. The existence of the SOCP termination zones provided strong reinforcement of the concept that spatially discrete groups of cells exist within the olive, each group providing climbing fibres to one (or in some cases two) longitudinal zones in the cortex. It should be noted however that the location of the SOCP zones is necessarily determined both by the olivocerebellar localisation and by the distribution within the olive of the terminals of the relevant groups of afferents to the olive. Thus, although it was (and continues to be) highly probable that each electrophysiologically defined SOCP termination zone is spatially congruent with one of the olivo-cerebellar zones it is still to be definitively demonstrated that the correspondence is always exact. For this reason a descriptive strategy has often been adopted of naming the olivocerebellar zones with upper case letters and the apparently coextensive SOCP zones with lower case letters. However, at least in the anterior lobe and the paramedian lobule in the cat it is probable that the distinction can now be discarded (and it will be below). At any rate, in studies in which the SOCP zones have been defined electrophysiologically and injections of WGA-HRP have been made that are confined or almost confined to a single zone the distribution of retrogradely labelled olivary neurones has been, with one specific and explicable exception (see next section), always in excellent accord with predictions deriving from knowledge of the olivocerebellar localisation per se (see refs. 25, 56-58 and Trott, Apps and Armstrong, unpublished observations).

The olivocerebellar topographical localisation deduced by Brodal and Kawamura (1980) in respect of the anterior lobe is summarized by Fig. 1 (their Fig. 17) and in respect of the paramedian lobule by Fig. 2 (their Fig. 22). These diagrams

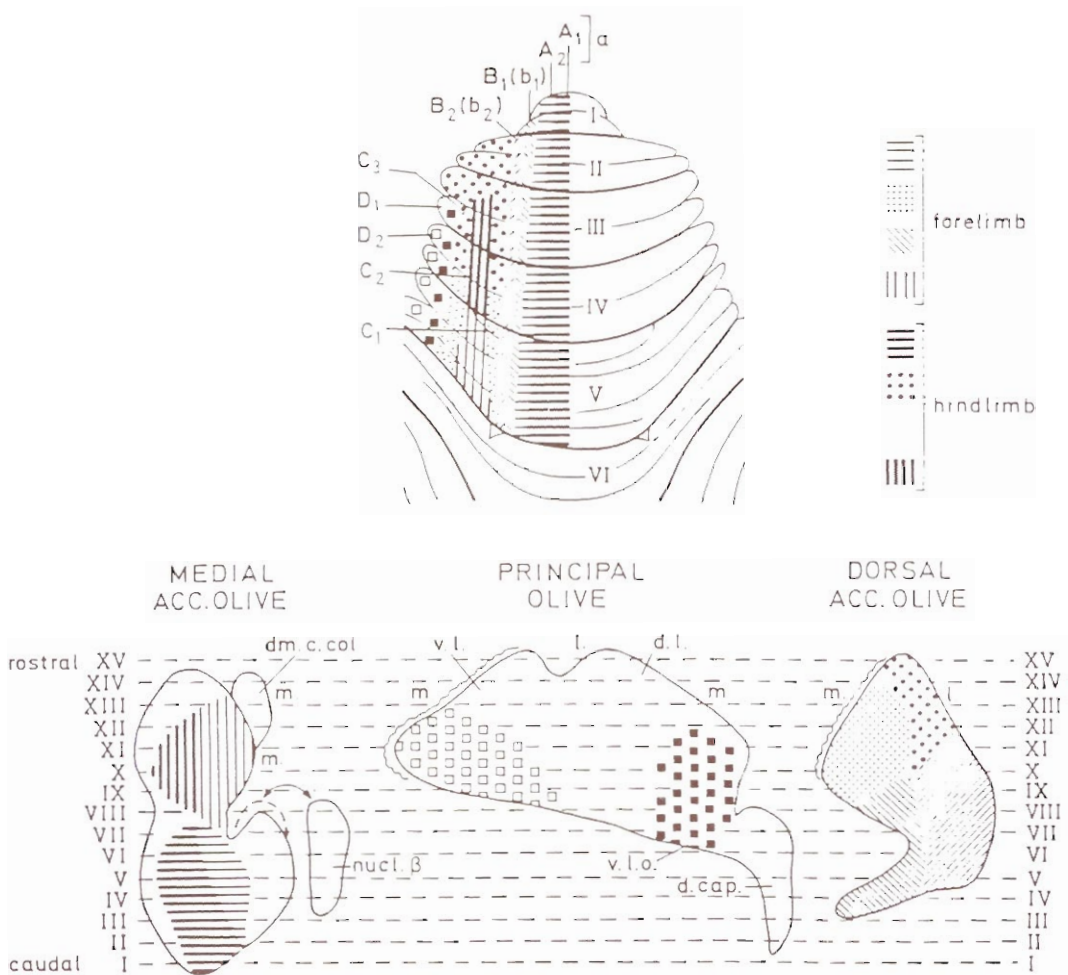

Fig. 1. - Topography of the olivary projections to the anterior lobe of the cat cerebellum as deduced by synthesizing data from HRP, tritiated leucine and electroanatomical studies.

Reproduced from Fig. 17 of Brodal and Kawamura (17). dm.c.col, dorsomedial cell column; v.l., ventral lamella of principal olive; d.l., dorsal lamella of principal olive; v.l.o., ventro-lateral outgrowth; d. cap., dorsal cap; m, medial; d, dorsal.

include, in addition to the C zones which are the focus of this review, two vermal (i.e. A and B) and two hemispherical (i.e. D<sub>1</sub> and D<sub>2</sub>) zones.

#### PROGRESS SINCE BRODAL AND KAWAMURA (1980)

The presence of an olivocerebellar localisation along the general lines of Figs. 1 and 2 appears now to be beyond serious dispute but since 1980 further studies

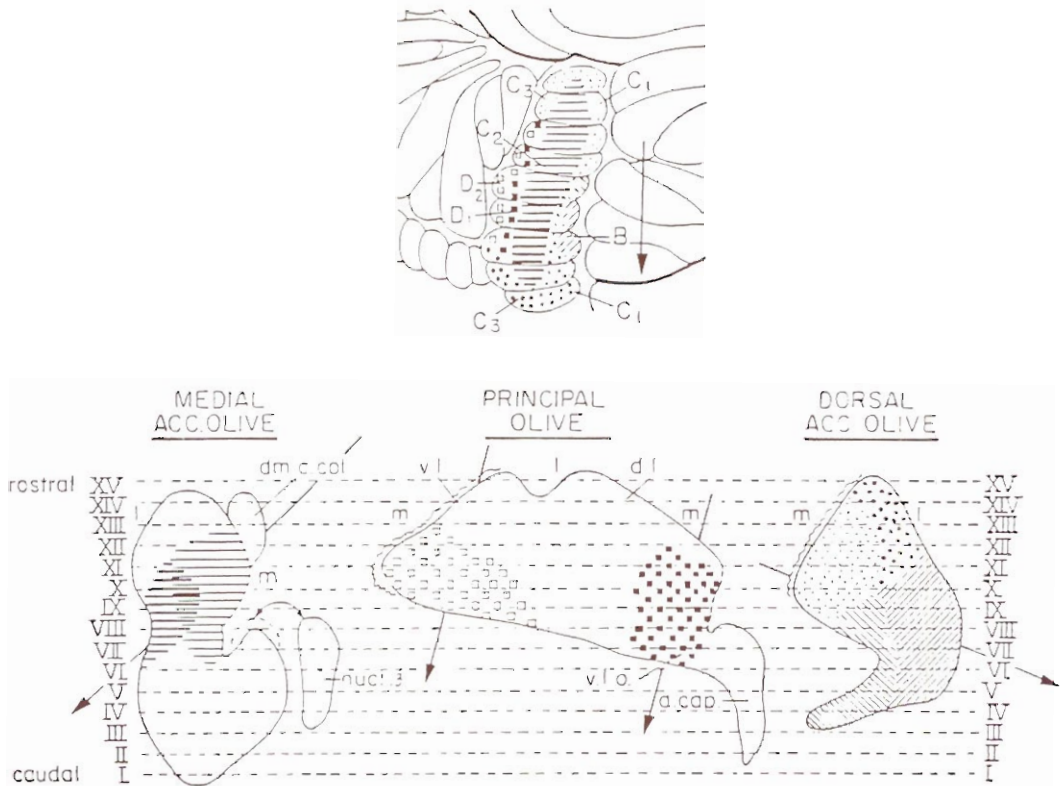

Fig. 2. - *Topography of the olivary projections to the paramedian lobule of the cat cerebellum as deduced by synthesizing data from HRP, tritiated leucine and electroanatomical studies.*

Reproduced from Fig. 22 of Brodal and Kawamura (17). Abbreviations as in Fig. 1. Arrows indicate the conclusion that progressively more caudal parts of the zones in the lobule are supplied from progressively more caudal in the corresponding olivary territory (see text).

have been carried out which have amplified and in places significantly modified the picture concerning olivary relationships with the C zones. Very detailed and comprehensive discussions have previously been provided by Voogd (63) and by Voogd, Hess and Marani (64) so that here attention will be focussed only on certain particular developments.

One such has stemmed from the advent of retrograde double-labelling techniques which allow the identification of individual neurones that provide axonal branches to two separate target areas. This technical advance has allowed anatomical confirmation of the electrophysiological evidence for the existence of olive cells providing climbing fibres to Purkinje cells that are widely separated along the rostro-caudal extent of a particular zone. It seems particularly appropriate that the first such demonstration was achieved by Brodal, Walberg, Berkley and Pelt (20) and was

indeed mentioned by Brodal and Kawamura. Since then, further evidence of longitudinal branching has been provided by fluorescent dye studies (54, 55).

Of equal significance, however, has been a series of thematically related investigations which began with an electrophysiological study of the anterior lobe by Ekerot and Larson (29, 30). This study confirmed and extended earlier observations (e.g. refs. 13 and 47) suggesting the existence in lobule V of the anterior lobe of an extra vermal SOCP termination zone, sandwiched between the A and B zones and termed by Ekerot and Larson the X zone. This work was noted by Brodal & Kawamura but the X zone was not incorporated into the schema of Fig. 1. The anatomical discreteness of the zone has since been amply confirmed (25, 59, 60, 63, 64). In the present context the real importance of this zone lies less in its existence than in the fact that its climbing fibres arise as branches of olivary axons which also project to the  $C_1$  paravermal zone. This feature was first mentioned in brief (28, 29) and it echoes the earlier demonstration that some olivary axons branch in the transverse plane to supply climbing fibres to both the  $C_1$  and the  $C_3$  zones (10, 12). Full details and much additional information were given in a later paper (31) in which convincing electrophysiological evidence was provided firstly for subdivision of both the  $C_1$  and the  $C_3$  zones in the anterior lobe into medial and lateral halves and secondly for the existence of olivary axons that branch so as to "link" certain cerebellar zones in pairs.

Such linkages were found between the  $D_2$  zone and the lateral half of the  $C_3$  zone, between the medial half of the  $C_3$  zone and the medial half of the  $C_1$  zone and between the lateral half of the  $C_1$  zone and the vermal X zone. The full significance of this medio-lateral linkage pattern is not yet understood but it may be noted that as a result of its existence some vermal and paravermal Purkinje cells and some hemispherical and paravermal Purkinje cells will be subject to identical patterns of climbing fibre input (always assuming that impulses in the parent olivocerebellar axon are securely propagated into each branch axon).

These findings prompted an attempt by Campbell and Armstrong (25) to define the location in the olive of the neurones projecting to the X zone and its paravermal partner, the lateral  $C_1$  zone. As in the work of Ekerot & Larson (21) the location of the zones was determined in each experiment by recording the highly characteristic climbing fibre field potentials evoked on the surface of the cerebellum by volleys set up in the SOCPs by electrical stimulation of forelimb cutaneous afferents. As shown by Ekerot and Larson (29, 30) both the X and the  $C_1$  zone (both halves) receive input from an SOCP ascending in the dorsal spinal funiculus while the flanking zones (B and A in the case of the X zone and  $C_2$  and B in the case of  $C_1$ ) do not. Once the zones had been located in lobule V of the anterior lobe a microinjection of WGA-HRP was placed in the centre of the width of the X zone or within the lateral  $C_1$  zone and after a suitable survival period the injection site and the retrogradely labelled olivary cells were visualized using the Mesulam method. This work revealed that the olivary projections to the two zones arise not from the rostral part of the dorsal accessory olive (DAO) as originally surmized (see ref. 17 and 29) but from the medial part of the medial

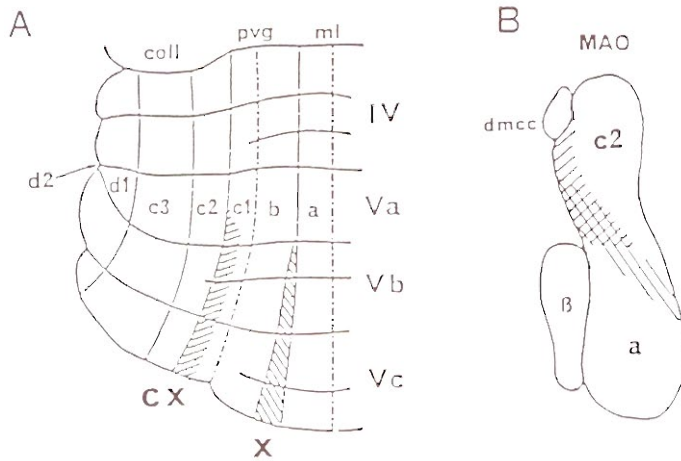

Fig. 3. - Origin in the rostral and middle parts of the medial accessory olive of the projections to the X and Cx zones in lobule V of the anterior lobe of the cat cerebellum as revealed by a combined electrophysiological/WGA-HRP study.

a and c<sub>2</sub> in B represent the regions of MAO that supply the corresponding cerebellar zones. dmcc, dorsomedial cell column; coll, inferior colliculus; pvgl, paravermal groove; ml, midline. Reproduced from Campbell and Armstrong (25).

accessory olive (MAO). As shown in Fig. 3 the X zone is supplied from cells at middle levels of the MAO while the lateral C<sub>1</sub> zone is supplied from a cell population centred further rostrally. It is presumed, though not yet verified by double-labelling, that the olivo-cerebellar axons that branch to innervate both the X and the lateral C<sub>1</sub> zone are from olive cells in the region where the X and the lateral C<sub>1</sub> representations overlap (the cross-hatched area in Fig. 3B).

Because there is general agreement that the medial C<sub>1</sub> zone is innervated from the rostral part of DAO, Campbell and Armstrong (25) suggested that lateral C<sub>1</sub> should be re-designated as a distinct zone — the Cx zone. In this connection it should be noted that because the adjacent C<sub>2</sub> zone is also supplied from the rostral part of MAO, the possibility may be entertained that the Cx zone should be regarded as a subdivision of C<sub>2</sub>. However, a subsequent orthograde transport study (<sup>3</sup>H leucine; autoradiography) has shown that both the Cx and the medial C<sub>1</sub> zone project to the anterior division of nucleus interpositus (59, 60). As the Purkinje cells of the C<sub>2</sub> zone are generally agreed to project to the posterior subdivision of interpositus there seems therefore to be a good case for regarding Cx as a distinct zone which most resembles the C<sub>2</sub> in respect of its olivo-cerebellar afferent connection but most resembles the medial C<sub>1</sub> zone in respect of its cortico-nuclear projection. Fig. 4 summarizes in diagrammatic form the olivary and the cortico-nuclear connections of the Cx zone in lobule V of the anterior lobe as presently understood and compares them with the corresponding connections for the other zones in lobule V.



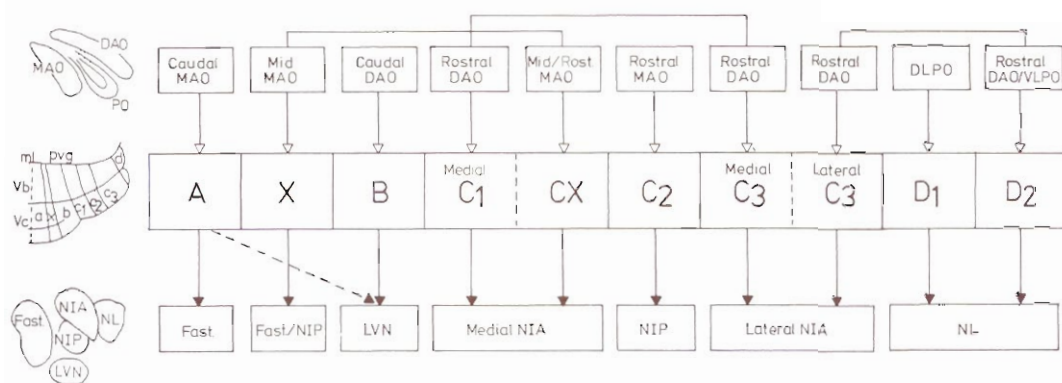

Fig. 4. -Organization of olivary projections to the different cerebellar cortical longitudinal zones in lobule V b/c of the anterior lobe in the cat cerebellum as understood at present. Also shown is the organization of the cortico-nuclear projections originating from the different zones.

Fast., NIA, NIP, NL and LVN are respectively nucleus fastigius, nucleus interpositus anterior, nucleus interpositus posterior, nucleus lateralis and lateral vestibular nucleus; ml, midline; pvg, paravermal groove.

More recently, another aspect of the work of Ekerot and Larson (31) has provoked a further study in our laboratory (see ref. 56). Despite the fact that the lateral C<sub>3</sub> zone and the medial C<sub>1</sub> zone both receive their climbing fibres from the rostral part of DAO Ekerot & Larson found no evidence for a branching linkage between these two zones (though such a link was evident between lateral C<sub>3</sub> and the D<sub>2</sub> zone and between medial C<sub>1</sub> and medial C<sub>3</sub>). This negative finding would seem to imply that the two zones receive their climbing fibres from different subpopulations of olive cells and a WGA-HRP study was therefore carried out to determine the relative locations in the rostral part of DAO of the cells supplying the medial C<sub>1</sub> zone, the medial C<sub>3</sub> and the lateral C<sub>3</sub> zones. As in the study by Campbell and Armstrong (25) the positions of the zones were delimited electrophysiologically in lobule V by setting up volleys in the relevant SOCPs and it must be noted that this approach only revealed the position of the whole of the classical C<sub>1</sub> zone (i.e. medial C<sub>1</sub> and C<sub>x</sub>) and the whole of the C<sub>3</sub> zone. These two were therefore subdivided on the basis of assuming that their medial and lateral parts were of equal width. Notwithstanding this limitation it seemed clear as shown by Fig. 5 that medial C<sub>1</sub> and medial C<sub>3</sub> are supplied from the same portion of DAO while the lateral C<sub>3</sub> zone is supplied from a distinct portion which lies further medially and extends less far caudally. It is of interest to note that these findings are in good accord with a deduction of Voogd (63) who states "my interpretation favours a more caudal origin [in DAO] of the fibres to C<sub>1</sub> and medial C<sub>3</sub> and a rostral origin of the fibres to lateral C<sub>3</sub> and the D<sub>2</sub> zone".

Note that the olivary territories corresponding to the half-zones extend rostro-caudally for c. 1.5 mm (6 levels) in the case of the lateral C<sub>3</sub> zone and for c. 2.5 mm (10 levels) in the case of the medial C<sub>1</sub> and medial C<sub>3</sub>. In each case this considerably exceeds the maximum extent of the territory in either the medio-



Fig. 5. -Olivary territories shown by a WGA-HRP study to project to the medial  $C_1$  (A), medial  $C_3$  (B) and lateral  $C_3$  (C) zones in lobule V b/c of the anterior lobe of the cat cerebellum.

Each column shows twelve equally spaced semidiagrammatic transverse sections through the rostral half of the inferior olive; antero-posterior stereotaxic levels are indicated. Each column represents the pooled data derived from the number of individual experiments shown in brackets. Reproduced with permission from Fig. 2 of Trott (56).

lateral or the dorso-ventral plane so that each half-zone is best described as supplied from a rostro-caudally oriented column of olivary neurones. Note also that the MAO territories supplying the X and C<sub>x</sub> zones as delimited by Campbell and Armstrong (25) were rather similar columns that in both cases extended rostro-caudally for c. 2.25 mm (cf. Fig. 3B).

Though the investigations discussed above have added significantly to our knowledge of the projections from the olive to the C zones and although the general outlines of the topographical relationships involved seem now to be quite well established, it is nevertheless clear that some questions remain unanswered that are potentially of considerable functional significance.

One such, arising from the work of Trott (56), is whether within the olivary territory that supplies medial C<sub>1</sub> and medial C<sub>3</sub> (and also within that supplying lateral C<sub>3</sub> and D<sub>2</sub>) there are some cells that project to only one of the two zones and others that project to both and, if this proves to be the case, whether these differently projecting neurones are differentially distributed. Retrograde double-labelling would seem to be the only technique currently available that might answer this problem, though given the tendency of fluorescent dye injections to produce large injection sites it may be necessary to employ fluorescent-labelled microspheres (40) as tracers and their utility for this purpose is currently being explored in our laboratory. A degree of differential distribution might in fact be expected (by analogy) in view of the fact that within MAO the populations of cells retrogradely labelled by injections into the X zone and the C<sub>x</sub> zone were found by Campbell and Armstrong (25) to overlap partially but not completely (see Fig. 3B). Moreover, in the case of the lateral C<sub>3</sub> and D<sub>2</sub> zones it appears that much of the innervation of the D<sub>2</sub> zone in anterior lobe and paramedian lobule derives not from rostral DAO but from the ventral lamella of the principal olive (see 65; 17 for discussion and refs., but for a contrary view see 53, 54). It may therefore be suspected that C<sub>3</sub>-D<sub>2</sub> "linking" cells will prove to be concentrated at the junctional region where rostral DAO fuses with the ventral lamella. If differential distribution does exist then zones linked or paired by branching of olivo-cerebellar axons are in fact only partially linked and therefore the two zones in each pair will receive via the climbing fibres information patterns that differ significantly.

A further and more major question that is currently unresolved will be the subject of the remainder of this review.

WHAT IS THE NATURE OF ANY FINE-GRAIN LOCALISATION THAT MIGHT EXIST WITHIN THE PROJECTION TO AN INDIVIDUAL CEREBELLAR ZONE FROM THE CORRESPONDING PART OF THE OLIVE?

This is a question that preoccupied Brodal and Kawamura (17) and it is one that gains in importance as a result of electrophysiological studies of the SOCPS by Oscarsson and his coworkers. In the C<sub>1</sub>, C<sub>3</sub> and D<sub>2</sub> termination zones for

the dorsal funiculus spino-olivocerebellar pathway (DF-SOCP) evidence has been provided by Ekerot and Larson (30) for medio-lateral division of each zone into longitudinally-running narrow strips in each of which the climbing fibres are activated from a different part of the periphery (as shown by electrical stimulation of different peripheral nerves or dorsal roots). These cortical strips show some overlapping in the mediolateral plane and do not extend the full length of the zone but their existence nevertheless indicates that within the DF-SOCP there is a detailed somatotopical organization.

Somewhat similarly Andersson and Oscarsson (3 and 4; see also ref. 2) have demonstrated for the ventral funiculus SOCPs terminating in the vermal B zone an arrangement such that as the zone is traversed from lateral to medial the input source changes from bilateral hindlimb, through bilateral forelimb and hindlimb in different proportions, to bilateral forelimb so that the zone is divisible into a series of sagittally running microzones. Although it must be kept in mind that these arrangements depend not only on the nature of the olivocerebellar localisation but also on the pattern of localisation present in the relevant groups of olivary afferents their existence does suggest that within each of several olivocerebellar projection zones (and perhaps therefore in all zones) there is a fine-grain localisation such that differently located groups of olive cells project to different subzones each of which occupies only a fraction of the width of the whole zone and each of which extends rostro-caudally across a number of folia. Oscarsson (49) has proposed that microzones may be fundamental functional units within the cerebellum, and it therefore becomes important to try to define the size, location and extent of the olivary cell groups corresponding to individual microzones.

It must, however, be admitted at the outset that the microzones so far encountered are so narrow (c. 100 $\mu$ m) that the spatial resolving power of current anatomical tracing techniques is barely, if at all, adequate to this task. Thus, although a body of relevant anatomical evidence does exist regarding detailed relationships between the C zones and the related portions of the olive (i.e. the rostral halves of the accessory olives) it does not serve to localize unequivocally the olivary territory corresponding to any single microzone. Nevertheless, it seems worthwhile now, as it did to Brodal and Kawamura (17), to review the evidence, some of which has accrued since 1980.

In fact, quite apart from the electrophysiological evidence regarding microzones, it is clear that some degree of what Brodal and Kawamura termed a "topical" relationship does exist within the olivary projections to single "Voogd" zones in the cerebellar cortex. A gross type of subdivision that has already been alluded to is well-attested for the C<sub>1</sub> and C<sub>3</sub> zones by the fact that the rostral part of these zones (in the forward lobules of the anterior lobe) and the part lying in the caudal folia of the paramedian lobule both receive "hindlimb" SOCP input and are linked by axonal branching (26, 54), while by contrast the parts of the zones in the rostral folia of the paramedian lobule and in lobule V of the anterior lobe both receive "forelimb" SOCP input and these two parts are again "linked" by olivary axonal branching (9-12, 26, 54). These "forelimb" and "hindlimb"

subdivisions receive their climbing fibres respectively from medial and lateral portions of rostral DAO as indicated in Fig. 1 (see also ref. 57).

In respect of the  $C_2$  zone a parallel division into "forelimb" and "hindlimb" regions seems also to exist. As implied by Figs. 1 and 2, Brodal and Kawamura concluded on the basis of evidence provided by Brodal and Walberg (18, 19) that these regions were supplied respectively from medially and laterally placed portions of rostral MAO and since then this picture has been confirmed by the retrograde fluorescent dye study of Rosina and Provini (54). It should be noted, however, that the division should not in the case of this zone be taken to imply that SOCP input to the two regions is confined respectively to forelimb and to hindlimb: electrophysiological evidence (42; Trott and Armstrong, unpublished observations) shows clearly that climbing fibres in all parts of the zone can be activated by nerve volleys originating in all four limbs. This circumstance can readily be explained by assuming that the relevant afferents to the olive provide terminals distributed throughout both the medial and the lateral portions of the area of rostral MAO devoted to the  $C_2$  zone.

In addition to these major subdivisions, however, there is anatomical evidence for some finer-grain localisation in the olivary projections to the C zones. Thus injections of HRP into different lobules of the anterior lobe were found by Brodal and Walberg (18) to result in rostral DAO in a pattern of retrograde labelling such that the cells projecting lobules II, III and IV appeared to form concentrations which overlapped significantly but were nevertheless centred successively further caudally. At the time it was concluded that this labelling was due to inclusion of vermal zone B within the injection sites but it is now evident that the labelling must have originated from the "hindlimb" part of the  $C_1$  zone.

In addition, microinjections of HRP into the  $C_1$  zone in different parts of the paramedian lobule were found by Brodal and Walberg (19) each to label a small group (of from two to 20 cells) in rostral DAO (their Fig. 3C) and there was little overlap in position between these groups. In interpreting these data Brodal and Kawamura concluded that three of the five available cases did not in fact relate to the  $C_1$  zone because the injections had been placed in a portion of the B zone which they believed to exist in the medialmost part of the paramedian lobule (see Fig. 2). However, it now seems clear (63; Trott and Armstrong, unpublished observations) that the B zone does not extend as far caudal as the paramedian lobule but terminates at the junction of lobules VI and VII so that all five cases are presumably relevant, as originally believed. Thus, the evidence of Brodal and Walberg (19) appears to support the existence of a fine-grain topical relationship between the rostral half of DAO and the  $C_1$  zone, with different groups of cells projecting to different folia within the zone (see DAO arrow in Fig. 2).

Brodal and Kawamura concluded that a topical relationship also exists for the  $C_2$  zone with olive cells projecting to different parts of this zone being differentially located within the rostral part of MAO. For the paramedian lobule part of the zone Brodal and Walberg (19) found that HRP injections into different folia led in rostral MAO to retrograde labelling of differently located groups of

neurones (see their Fig. 3A) distributed by and large in such a way as to suggest that progressively more caudal folia receive their climbing fibres from progressively more caudolateral areas within rostral MAO (see MAO arrow in Fig. 2).

Further evidence relevant to localisation in the olivary projections to the C zones is available from the anterograde degeneration/transport studies of Groenewegen and Voogd (34) and Groenewegen, Voogd and Freedman (35). These investigations abundantly confirmed the division of the C<sub>1</sub> and C<sub>3</sub> cortical zones into "hindlimb" and "forelimb" sections supplied from different groups of cells in the rostral dorsal accessory olive and also showed that the C<sub>2</sub> zone is divisible into a section which includes anterior lobe and paramedian lobule (supplied from the caudal part of rostral MAO) and a section in the ansiform lobule and paraflocculus (supplied from further rostrally).

However, apart from the demonstration of these large-scale localisations, only scant evidence was provided for any fine-grain topical relationships in the projections. Thus in regard to the C<sub>2</sub> zone, case H8832 (Fig. 21 of ref. 34) led to labelling in the anterior lobe part of the zone but not in its paramedian lobule part (though it is noteworthy that in this case the survival period after tracer injection was only 6 hours). In all other cases (see Table 2 of ref. 34) the anterior lobe and the paramedian lobule parts of the C<sub>2</sub> zone were labelled (or showed degenerating climbing fibres) together.

In regard to the C<sub>1</sub> and C<sub>3</sub> zones the relevant evidence appears in Table 5 of Groenewegen, Voogd and Freedman (35) and there were only two cases in which labelling failed to extend throughout the whole rostrocaudal extent of either the "hindlimb" or the "forelimb" sections of these zones. In one of these cases (H9306 II) the Table indicates that label was present only in the C<sub>3</sub> zone and only in lobules II and IV of the anterior lobe. However, the text indicates that the tracer injection in this case led to only weak labelling in the olive and also that some labelled climbing fibres were present in the C<sub>3</sub> zone in rostral paramedian lobule and in the C<sub>1</sub> zone in both the rostral and the caudal folia of the lobule. The other relevant case (H8789) led to labelling of the C<sub>1</sub> and C<sub>3</sub> zones throughout the anterior lobe and also in rostral paramedian lobule; only in caudal paramedian lobule was labelling absent.

These cases must be considered alongside several others in which injections or lesions involving even quite small parts of rostral MAO (e.g. cases 9252, 9201, 7777, 8461, 9306I) or rostral DAO (e.g. cases 9211, 9048, 9318, 9295II, 8784, 9317II) led respectively to labelling or degeneration throughout the C<sub>2</sub> zone in anterior lobe and paramedian lobule or throughout the "hindlimb" or "forelimb" parts of the C<sub>1</sub> and C<sub>3</sub> zones. Particularly important to note is the fact that non-overlapping small portions of rostral MAO (cases 9252 and 7777) or rostral DAO (compare case 9048 and 9317II) sometimes appeared to project to the whole rostro-caudal extent of the C<sub>2</sub> zone or the C<sub>1</sub>/C<sub>3</sub> zones respectively.

Such findings conflict directly with the notion of an ordered fine grain localisation organized on a folium-by-folium (i.e. rostro-caudal) basis as suggested by the results of Brodal and Walberg (19) and some explanation must be sought

for the discrepancy. In this connection it is important that in axonal transport studies false-positive results are unlikely to arise whilst false-negatives could easily occur (if, for example, labelling were to occur at a level below detection threshold). Bearing this in mind two observations would seem to be crucial: first, that injections of orthograde tracer restricted to only a part of one olivary subdivision can frequently lead to labelling of climbing fibres throughout much or all of the rostro-caudal extent of the relevant cortical zone; and second, that much or all of the rostro-caudal extent of a cortical zone can be labelled from injection sites in different parts of the relevant olivary subdivision. These observations must imply that in all parts of rostral DAO and rostral MAO there are substantial numbers of olivary neurones with axons that branch very widely in the rostrocaudal cerebellar plane (an organizational principle that is, as already discussed, abundantly supported both by electrophysiological evidence and by the findings of retrograde double labelling studies). If this is the case then *retrograde* label injected at different rostrocaudal positions along one of the C zones *ought* to produce labelling in populations of olive cells that a) overlap rather heavily and b) are distributed throughout much or all of the relevant olivary subdivision.

In the cases presented by Brodal and Walberg (18, 19) this was obviously not the case but a partial explanation may lie in the fact that in these studies as in many others in the mid-1970s unconjugated HRP was used as the tracer and the Graham and Karnovsky method of processing was employed to visualize it. This methodology is now well known to be less sensitive than the use of WGA-HRP combined with the Mesulam processing technique. It may be, therefore, that only those olive cells were detectable in which retrograde labelling was at its strongest. Such cells might be those providing more than one climbing fibre within the compass of the injection site — perhaps as a result of the kind of “close-range” or local axonal branching of the kind reported by Fox, Andrade and Schwyn (33), Desclin (27) and Palay and Chan-Palay (51). Olive cells providing only one branch to the injection site (and perhaps located away from the detectably labelled cells) might have been labelled too weakly to be detectable.

Additional evidence relevant to the problem of localisation in the olivary projection to the C zones has been provided by retrograde labelling studies in which two (53, 54) or three (55) fluorescent dyes were employed, injected separately at different rostrocaudal levels within the C zones. These experiments were capable of revealing the distributions of cells labelled from only one injection site (single labelled cells) or from two or all three sites (double-and triple-labelled cells respectively). Anatomical evidence was provided, therefore, not only regarding the distribution of the cells projecting to a chosen part of a zone but also regarding the extent to which such cells might have axons branching to provide additional climbing fibres to other parts of the zone. The injection sites were sufficiently large to involve all the C zones so that each experiment provided information regarding the olivary projections to each C zone.

The first of these studies (54) again confirmed the division of the C<sub>3</sub> and (medial) C<sub>1</sub> zones into “forelimb” and “hindlimb” portions respectively supplied from

the rostromedial and caudolateral portions of rostral DAO. It confirmed also the existence within each portion of abundant axonal branching in the sagittal plane and conversely gave no evidence for branching linkage between the hindlimb and forelimb portions. This study also provided evidence for a segregation within rostral MAO such that cells projecting to a "hindlimb" part of the  $C_2$  zone (i.e. to this zone where it is present in rostral anterior lobe and the caudal folia of the paramedian lobule) lay in the lateral half of the caudal two-thirds of rostral MAO, while cells projecting to a "forelimb" part of  $C_2$  (i.e. to the parts of the zone in caudal anterior lobe and rostral paramedian lobule) were located more medially. In a modest sized area of overlap between the two olivary populations a few cells projected to both "hindlimb" and "forelimb" parts of the zone.

The second study (55) was confined largely to lobule V of the anterior lobe and to the rostral half of the paramedian lobule. In all experiments, tracer injected into the anterior lobe led to labelling of neurones distributed throughout the "forelimb" parts of both rostral DAO and rostral MAO so that no "fine-grain" localisation was revealed in the projections of these subnuclei to the anterior lobe.

For the paramedian lobule, however, the case was different: when different tracers were injected into two different folia the two populations of single-labelled cells were distributed both in rostral MAO and in rostral DAO in non-overlapping fashion and there were very few, if any, double-labelled cells. Overall, a pattern emerged for the  $C_2$  zone such that the most rostral folium (folium one) was innervated from the rostralateral part of the caudal two thirds of rostral MAO, folium two was supplied from cells at approximately the same rostro-caudal level but located more medially and folium three was supplied from more caudally in rostral MAO. It should be noted, however, that it was possible for two injections, together involving only part of the "forelimb" region of the  $C_2$  zone, to label cells distributed virtually throughout the part of rostral MAO that supplies the "forelimb"  $C_2$  zone as a whole (cases 111 and 134; respectively their Figs. 6 and 7). It follows that even if the projection to the  $C_2$  zone in "forelimb" paramedian lobule is more "topical" than that to the "forelimb" anterior lobe, it cannot be organized on anything approaching a strictly non-overlapping point-to-point basis. As regards the forelimb parts of the  $C_3$  and medial  $C_1$  zones in the paramedian lobule the findings were similar in again suggesting fairly complete segregation within the forelimb region of rostral DAO of the cells labelled from two different folia — but again it may be noted that it was possible (see Case 111; their Fig. 6) for an injection involving a single folium to produce labelling of cells over a large part of this region.

Other aspects of the results, including the numbers and distribution of triple-labelled cells, were used by Rosina and Provini to deduce that one pattern of axonal branching common in relation to both the  $C_2$  and the  $C_1/C_3$  zones is the provision by a single olivary neurone of a branch to each of two folia in the anterior lobe plus one branch to the paramedian lobule. It was further argued that if each branch in turn provides three intrafolial or "local" branches, then each olive cell would provide nine climbing fibres, a figure which comes close



to accounting for the ten to one preponderance of Purkinje cells over olivary neurones in the cat (32, 45, 52).

A fourth body of evidence which bears on the problem of fine-grain localisation is provided by recent studies in our laboratory in which small injections of WGA-HRP have been made into the tip of a single folium in the C zones in lobule V of the anterior lobe and in the paramedian lobule. In these studies the zones have first been electrophysiologically identified by producing volleys in the relevant spino-olivocerebellar paths (see refs. 25, 56, 57, 59, 60) and the Mesulam technique has been used to reveal the tracer. In some cases the effective injection site was confined, or almost confined, to the width of a single zone as shown for injections into the C<sub>2</sub> or the C<sub>3</sub> zone by the fact that labelling was confined to, or mainly within, rostral MAO or rostral DAO respectively. In the C<sub>1</sub> zone in the anterior lobe the injection sites usually involved both half-zones (i.e. both the Cx and the medial C<sub>1</sub> zones) as shown by the presence of retrograde labelling both in the Cx-related part of rostral MAO and in rostral DAO. However, it was occasionally possible to produce label confined to the medial C<sub>1</sub> zone as shown by the absence of labelling in rostral MAO.

The findings after injections into the medial and lateral C<sub>3</sub> zones and into the medial C<sub>1</sub> zone in lobule V of the anterior lobe have been presented by Trott (56) and were reproduced above as Fig. 5. Note that the territory in rostral DAO covered by combining the cell columns related to the lateral C<sub>3</sub> zone and the medial C<sub>1</sub>/medial C<sub>3</sub> zones is in excellent agreement with the representations deduced for the whole of their "forelimb" part of the C<sub>1</sub> and C<sub>3</sub> zones by Brodal and Kawamura (17), Groenewegen, Voogd and Freedman (35) and Rosina and Provini (54). In Fig. 5 the olivary territories innervating each of the three half zones were deduced by pooling a number of experiments and for present purposes it is particularly significant that in each individual experiment the labelled olive cells were distributed throughout a considerable proportion of the appropriate olivary column. Because in each experiment the olivary region labelled must define the minimum extent of the territory that supplies climbing fibres to the tip of one folium this finding appears definitely to exclude any point-to-point representation in rostral DAO of different rostro-caudal levels within the "forelimb" part of the medial C<sub>1</sub> zone.

After injections in the C<sub>1</sub> zone in the rostral part of the paramedian lobule (57) the results have been essentially similar: injection sites confined to a single folium were capable of producing labelling throughout much of the forelimb part of rostral DAO. This result is readily reconciled with the findings of Groenewegen, Voogd and Freedman (35) but it diverges markedly from the findings of both Brodal and Walberg (19) and Rosina and Provini (55), which favour a folium-by-folium projection to the C<sub>1</sub> zone in "forelimb" paramedian lobule. This discrepancy cannot currently be explained except on the supposition that in this particular application the sensitivity of the WGA-HRP/Mesulam technique may exceed that of the fluorescent dye technique as well as that of the HRP/Graham and Karnovsky method.

For the  $C_2$  zone the findings (Trott and Apps, in preparation) have again been similar: among experiments involving injections in either lobule V or the rostral part of the paramedian lobule there have been several in which an injection into a single folium led to rather widespread labelling in the part of rostral MAO defined by Brodal and Kawamura (17) and by Rosina and Provini (54, 55) as projecting to the forelimb part of the  $C_2$  zone. Fig. 6 shows two example cases. In the experiment of Fig. 6A the injection site involved the  $C_2$  zone in a single folium in lobule Vc whilst in that of Fig. 6B the site involved the same zone in the third (and to a small extent also the second) folium, of the paramedian lobule. Fig. 6C shows the area of rostral MAO which, according to Campbell and Armstrong (25) projects to the Cx zone in lobule V and comparison suggests that some of the labelling in Fig. 6A is attributable to tracer spread into the Cx zone. However, even if labelling in this area is ignored it is nevertheless evident that both cases involved quite extensive labelling within MAO. It may be noted also that although in Fig. 6B the labelling at most rostro-caudal levels was centred more ventrally than in Fig. 6A there was nevertheless considerable overlap between the two distributions confirming that the parts of the  $C_2$  zone lying in lobule V and in rostral paramedian lobule receive their climbing fibres from overlapping populations of olive cells.

Whilst up to now this account has argued against there being much fine-grain localisation in the projections from the inferior olive to different rostrocaudal levels within the "forelimb" and the "hindlimb" parts of the C zones there are certain findings which nevertheless remain to be explained. Even if the HRP/Graham & Karnovsky methodology used by Brodal and Walberg (19) is limited in its sensitivity the fact remains that the olive cells that were labelled in their experiments formed quite tight clusters in different part of rostral MAO and DAO. In addition, in our own experiments there was a general tendency for smaller injection sites to produce labelling at fewer rostrocaudal levels. These findings undeniably suggest that some kind of topical relationship may exist that is near the limit of detection using current tracer methods.

The nature of this localisation remains at present uncertain but although the unravelling of its details is likely to be both difficult and time-consuming it is nevertheless a high-priority task in view of its likely relevance to the task of understanding more fully the anatomical basis and the functional significance of Oscarsson's (49) microzones. It has previously been suggested (7) on the basis of indirect evidence regarding localisation in the direct spino-olivary projections to caudal MAO and to rostral DAO — combined with the evidence of Brodal and Walberg (18) — that individual microzones might receive their climbing fibres from a narrow rostro-caudal column of olive cells confined within the larger column that supplies the zone as a whole.

However, some more direct evidence is currently accruing from WGA-HRP studies of the olivocerebellar projections in our laboratory (Trott, Apps and Armstrong, in preparation). Although analysis of the material is not yet complete it is perhaps permissible here to state that for some zones it seems that the latero-



Fig. 6. - Territories in the rostral half of the medial accessory olive containing cells retrogradely labelled after small injections of WGA-HRP into the cerebellar cortex.

A shows the MAO territory labelled in an experiment in which the injection site involved the  $C_2$  zone in a single folium of lobule Vc. B shows MAO labelling from an injection site involving the  $C_2$  zone in the third most rostral folium (and part of the second folium) in the paramedian lobule. C shows the Cx-related part of MAO as deduced by Campbell and Armstrong (25).

medial dimension of the zone may be mapped across the rostro-caudal dimension of the corresponding olivary cell column. Thus, for example, in the case of the C<sub>x</sub> zone in lobule V it appears that when the zone is encroached on by injection sites in the next most medial zone (i.e. medial C<sub>1</sub>), labelling in the C<sub>x</sub>-related portion of rostral MAO extends less far rostrally than in cases in which C<sub>x</sub> is encroached on from the next most lateral zone (i.e. C<sub>2</sub>).

How widespread such an arrangement might be within the olivary columns projecting to other C zones is not yet clear but it may be noted that Brodal and Walberg (19) made microinjections of HRP into the middle of each of several paramedian lobule folia and these produced islands of labelled cells in the C<sub>2</sub> part of rostral MAO. Of these six cases (see their Fig. 3A) one injection was into "hindlimb" (i.e. caudal) paramedian lobule but the others were further rostral (cases numbered 1 to 5 with an injection into folium two as the most rostral in the series). Brodal and Walberg commented that, in general, the more rostral the folium involved the more rostrally placed in MAO were the resultant labelled cells. However, the ordering was by no means precise because case 5 led to labelling more rostral than in cases 3 and 4 (and even perhaps slightly rostral to case 2). Inspection of their Fig. 3A suggests to the present author that although no clear decision can be reached, the results could be consistent with an alternative scheme in which rostral in MAO corresponds with lateral in the C<sub>2</sub> zone. This possibility perhaps receives some support from their Fig. 4A, where an injection into folium one led to labelling no further rostrally than for case 1 in Fig. 3A but distinctly further medially.

The above relates specifically to the relationships between rostral MAO and the C<sub>x</sub> and C<sub>2</sub> zones and it is therefore of interest to enquire whether any similar evidence exists in respect of rostral DAO and the C<sub>1</sub>/C<sub>3</sub> zones. Here, it may be noted that Brodal and Walberg (19) reported three experiments (745R, 746R and 740) each involving a microinjection of HRP into the C<sub>1</sub> zone in the same caudal folium in the paramedian lobule. One of these (746R) was distinctly further medial in the folium than the other two and it is interesting that the resulting small island of labelled cells (in the "hindlimb" part of rostral DAO) was caudal to the islands in the other two cases.

#### CONCLUSIONS

To summarise, it appears that the "forelimb" and "hindlimb" parts of the C<sub>x</sub>, the C<sub>2</sub>, the medial C<sub>1</sub>/medial C<sub>3</sub> and the lateral C<sub>3</sub> zones each receive their climbing fibres from a separate rostro-caudally orientated column of cells in rostral DAO or MAO (the shortest column being apparently that which corresponds to the "forelimb" C<sub>2</sub> zone). Within at least some of these columns there is evidence that is suggestive of a finer-grain olivo-cerebellar topography and there are hints (but not yet more than hints) that this may be such that the lateral-to-medial dimension within the cerebellar zone is mapped by the rostro-caudal dimension

within the corresponding olivary column. If this is indeed the case then successively more lateral cerebellar microzones would be represented by successively more rostral groups of cells within the column supplying the zone as a whole.

In regard to the manner in which the *rostro-caudal* dimension of the cerebellar zone may be mapped, the finding that a WGA-HRP injection in a single folium often leads to labelling of much or even sometimes all of the rostro-caudal extent of the relevant olivary column seems inevitably to imply that the rostro-caudal dimension of the zone is not mapped in the olive in any ordered point-to-point sense at all but that its elongated shape results from the widespread branching of olivary axons in the sagittal plane. In other words, cells in the rostral or the caudal part of the olivary territory are enabled, by virtue of such branching, to innervate Purkinje cells distributed in respectively the lateral or the medial part of the zone in many or all of the folia included in the length of the zone. This is not, of course, to claim that the axons of all individual olive cells necessarily branch equally often or equally widely in the sagittal plane. Some which innervate cells in a few folia may be intermingled with others whose branches are more widely distributed. Moreover, the folia receiving branches from a single cell might be either juxtaposed within that zone or non-contiguous.

Finally, it should be stressed that attention has been confined here entirely to the paravermal cortex and the rostral parts of the accessory olives. How far these regions may differ organizationally from other parts of the olivocerebellar system has not been discussed and in fact for many areas the available evidence is insufficiently detailed to throw much light on any fine-grain localisation that may exist. In addition, no attempt has been made here to integrate our knowledge of spatial localisation in the olivocerebellar projection with information regarding patterns of localisation in the various afferent projections to the olive. Nor have comparisons been drawn with findings made in species other than the cat, though it is noteworthy that the results of some recent WGA-HRP studies in the rat (5, 23, 24) have been interpreted as showing that several different sagittal zones, corresponding in many respects to the Voogd zones in the cat, each receive their climbing fibres from a rostro-caudal columnar territory within the contralateral inferior olive. Moreover, for an olivary column in caudal MAO that projects to vermal zone A it has been concluded (see ref. 23) that the rostral and caudal levels within the column project respectively to the lateral and medial parts of the zone.

That within a single cerebellar zone progressively more lateral microzones may be represented progressively more rostrally in the relevant olivary cell column is perhaps in functional terms the most important possibility to be raised in the present account, but it would be wise to recognize that because of the limited spatial resolving power of current tracing techniques the evidence yet available would be very far from adequate to convince Alf Brodal.

*Acknowledgements.* — I wish to thank my colleagues Dr. Judy R. Trott and Dr. R. Apps for permission to refer to results both published and unpublished; also Mrs. L. Amos and Mrs. J. Parr - Buman respectively for expert technical and secretarial assistance.

## REFERENCES

1. ALLEN, G.I. and TSUKAHARA, N. Cerebrocerebellar communication systems. *Physiol. Rev.*, **54**: 957-1006, 1974.
2. ANDERSSON, G. and ERIKSSON, L. Spinal, trigeminal and cortical climbing fibre paths to the lateral vermis of the cerebellar anterior lobe in the cat. *Exp. Brain Res.*, **44**: 71-81, 1981.
3. ANDERSSON, G. and OSCARSSON, O. Projections to lateral vestibular nucleus from cerebellar climbing fiber zones. *Exp. Brain Res.*, **32**: 549-564, 1978.
4. ANDERSSON, G. and OSCARSSON, O. Climbing fiber microzones in cerebellar vermis and their projection to different groups of cells in the lateral vestibular nucleus. *Exp. Brain Res.*, **32**: 565-579, 1978.
5. APPS, R. The inferior olive projection to the posterior lobe vermis of the rat. *Europ. J. Neurosci.*, **1**: 10, 6, 1989.
6. ARMSTRONG, D.M. Functional significance of connections of the inferior olive. *Physiol. Rev.*, **54**: 358-417, 1974.
7. ARMSTRONG, D.M., CAMPBELL, N.C., EDGLEY, S.A., SCHILD, R.F. and TROTTI, J.R. Investigations of the olivocerebellar and spino-olivary pathways. In: PALAY, S.L., and CHAN-PALAY, V. (Eds.), *The Cerebellum: New vistas. Exp. Brain Res. (Suppl.)*, **6**: 195-232. Springer-Verlag, Berlin, Heidelberg, New York, 1982.
8. ARMSTRONG, D.M., HARVEY, R.J., and SCHILD, R.F. Branching of individual olivocerebellar axons to terminate in more than one subdivision of the feline cerebellar cortex. *J. Physiol., Lond.*, **202**: 106-108P, 1969.
9. ARMSTRONG, D.M., HARVEY, R.J. AND SCHILD, R.F. Distribution in the anterior lobe of branches of climbing fibres to the paramedian lobule. *Brain Res.*, **25**: 203-206, 1971.
10. ARMSTRONG, D.M., HARVEY, R.J. and SCHILD, R.F. Branching of inferior olivary axons to terminate in different folia, lobules or lobes of the cerebellum. *Brain Res.*, **54**: 365-371, 1973.
11. ARMSTRONG, D.M., HARVEY, R.J., and SCHILD R.F. Cerebello-cerebellar responses mediated via climbing fibres. *Exp. Brain Res.* **18**: 19-30, 1973.
12. ARMSTRONG, D.M., HARVEY, R.J. and SCHILD R.F. The spatial organization of climbing fibre branching in the cat cerebellum. *Exp. Brain Res.*, **18**: 40-58, 1973.
13. ARMSTRONG, D.M., HARVEY, R.J. and SCHILD R.F. Spino-olivocerebellar pathways to the posterior lobe of the cat cerebellum. *Exp. Brain Res.*, **18**: 1-18, 1973.
14. ARMSTRONG, D.M., HARVEY, R.J. and SCHILD R.F. Topographical localization in the olivo-cerebellar projection: An electrophysiological study in the cat. *J. comp. Neurol.*, **154**: 287-302, 1974.
15. BRODAL, A. Experimentelle Untersuchungen über die olivocerebellare Lokalisation. *Z. Ges. Neurol. Psychiat.*, **169**: 1-153, 1940.
16. BRODAL, A. The olivo-cerebellar projection in the cat as studied with the method of retrograde axonal transport of horseradish peroxidase. II. The projection to the uvula. *J. comp. Neurol.*, **166**: 417-426, 1976.
17. BRODAL, A. and KAWAMURA, K. Olivocerebellar projection: A review. In: BRODAL, A., HILLO, W., VAN LIMBORGH, J., ORTMANN, R., SCHIEBLER, T.H., TÖNDURY, G. and WOLFF, E., (Eds.) *Advances in Anatomy, Embryology and Cell Biology*. Vol. 64, pp. 1-140. Berlin, Heidelberg, New York, Springer-Verlag, 1980.
18. BRODAL, A. and WALBERG, F. The olivocerebellar projection in the cat studied with the method of retrograde axonal transport of horseradish peroxidase. IV. The projection to the anterior lobe. *J. comp. Neurol.*, **172**: 85-108, 1977.
19. BRODAL, A. and WALBERG, F. The olivocerebellar projection in the cat studied with the method of retrograde axonal transport of horseradish peroxidase. VI. The projection onto longitudinal zones of the paramedian lobule. *J. comp. Neurol.*, **176**: 281-294, 1977.

20. BRODAL, A., WALBERG, F., BERKLEY, K.J. and PELT, A. Anatomical demonstration of branching olivocerebellar fibres by means of a double retrograde labelling technique. *Neuroscience*, **5**: 2193-2202, 1980.
21. BRODAL, A., WALBERG, F. and HODDEVIK, G.H. The olivocerebellar projection in the cat studied with the method of retrograde axonal transport of horseradish peroxidase. I. The projection to the paramedian lobule. *J. Comp. Neurol.* **164**: 449-470, 1975.
22. BROOKS, V.B. *The Neural Basis of Motor Control*. Oxford, Oxford Univ. Press, 1986.
23. BUISSERET-DELMAS, C. Sagittal organization of the olivocerebello-nuclear pathway in the rat. I. Connections with the nucleus fastigii and the nucleus vestibularis lateralis. *Neurosci. Res.*, **5**: 475-493, 1988.
24. BUISSERET-DELMAS, C. Sagittal organization of the olivocerebello-nuclear pathway in the rat. II. Connections with the nucleus interpositus. *Neurosci. Res.*, **5**: 494-512, 1988.
25. CAMPBELL, N.C. and ARMSTRONG, D.M. Origin in the medial accessory olive of climbing fibres to the x and lateral c, zones of the cat cerebellum: a combined electrophysiological/WGA-HRP investigation. *Exp. Brain Res.*, **58**: 520-531, 1985.
26. COOKE, J.D., OSCARSSON O. and SJÖLUND, B. Termination of climbing fibre paths in paramedian lobule. *Acta physiol. scand.*, **84**: 37A-38A, 1972.
27. DESCLIN, J.C. Histological evidence supporting the inferior olive as the major source of cerebellar climbing fibers in rat. *Brain Res.*, **77**: 365-384, 1974.
28. EKEROT, C.-F. and LARSON, B. Three sagittal zones in the cerebellar anterior lobe innervated by a common group of climbing fibres. *Proc. Int. Union Physiol. Sci., Paris.*, **13**: 208, 1977.
29. EKEROT, C.-F. and LARSON, B. The dorsal spino-olivo-cerebellar system in the cat. I. Functional organization and termination in the anterior lobe. *Exp. Brain Res.*, **36**: 201-217, 1979.
30. EKEROT, C.-F. and LARSON, B. The dorsal spino-olivo-cerebellar system in the cat. II. Somatotopical organization. *Exp. Brain Res.*, **36**: 219-232, 1979.
31. EKEROT, C.-F. and LARSON B. Branching of olivary axons to innervate pairs of sagittal zones in the cerebellar anterior lobe of the cat. *Exp. Brain Res.*, **48**: 185-198, 1982.
32. ESCOBAR, A., SAMPEDRO, E.D. and DOW, R.S. Quantitative data on the inferior olivary nucleus in man, cat and vampire bat. *J. comp. Neurol.*, **132**: 397-404, 1968.
33. FOX, C.A., ANDRADE, A. and SCHWYN, R.C. Climbing fibre branching in the granular layer. Pp. 603-611. In: LLINÁS, R. (Ed.) *Neurobiology of Cerebellar Evolution and Development*. Chicago, Amer. Med. Assoc. 1969.
34. GROENEWEGEN, H.J. and VOOGD, J. The parasagittal zonation within the olivocerebellar projection. I. Climbing fiber distribution in the vermis of cat cerebellum. *J. comp. Neurol.*, **174**: 417-488, 1977.
35. GROENEWEGEN, H.J. VOOGD J. and FREEDMAN, S.L. The parasagittal zonation within the olivocerebellar projection. II. Climbing fiber distribution in the intermediate and hemispheric parts of cat cerebellum. *J. comp. Neurol.*, **183**: 551-602, 1979.
36. HODDEVIK, G.H. and BRODAL, A. The olivocerebellar projection studied with the method of retrograde axonal transport of horseradish peroxidase. V. The projection to the flocculonodular lobe and the paraflocculus in the rabbit. *J. comp. Neurol.*, **176**: 269-280, 1977.
37. HODDEVIK, G.H., BRODAL, A. and WALBERG, F. The olivocerebellar projection in the cat studied with the method of retrograde axonal transport of horseradish peroxidase. III. The projection to the vermal visual area. *J. comp. Neurol.*, **169**: 155-170, 1976.
38. JANSEN, J. and BRODAL, A. Experimental studies on the intrinsic fibers of the cerebellum. II. The corticonuclear projection. *J. comp. Neurol.*, **73**: 267-321, 1940.
39. JANSEN J. and BRODAL, A. *Aspects of Cerebellar Anatomy*. Oslo, Johan Grundt Tanum, 1954.
40. KATZ, L.C., BURKHALTER, A. and DREYER, W.J. Fluorescent latex microspheres as

- a retrograde neuronal marker for in vivo and in vitro studies of visual cortex. *Nature*, **310**: 498-500, 1984.
41. KOTCHABHAKDI, N., WALBERG, F. and BRODAL, A. The olivocerebellar projection in the cat studied with the method of retrograde axonal transport of horseradish peroxidase. VII. The projection to lobulus simplex, crus I and II. *J. comp. Neurol.*, **182**: 293-314, 1978.
  42. LARSON, B., MILLER, S. and OSCARSSON, O. A spinocerebellar climbing fibre path activated by the flexor reflex afferents from all four limbs. *J. Physiol., Lond.*, **203**: 641-649, 1969.
  43. MILES, T.S. and WIESENDANGER, M. Organization of climbing fibre projections to the cerebellar cortex from trigeminal cutaneous afferents and from the SI face area of the cerebral cortex in the cat. *J. Physiol., Lond.*, **245**: 409-424, 1975.
  44. MILES, T.S. and WIESENDANGER, M. Climbing fiber input to cerebellar Purkinje cells from trigeminal cutaneous afferents and the SI face area of the cerebral cortex in the cat. *J. Physiol., Lond.*, **245**: 425-445, 1975.
  45. MLONYENI, M. The number of Purkinje cells and inferior olivary neurones in the cat. *J. comp. Neurol.*, **147**: 1-10, 1973.
  46. OSCARSSON, O. The sagittal organization of the cerebellar anterior lobe as revealed by the projection patterns of the climbing fiber system. Pp. 525-537. In: LLINÁS, R. (Ed.) *Neurobiology of Cerebellar Evolution and Development*. Chicago, Amer. Med. Ass., 1969.
  47. OSCARSSON, O. Termination and functional organization of the dorsal spino-olivocerebellar path. *J. Physiol., Lond.*, **200**: 129-149, 1969.
  48. OSCARSSON, O. Functional organization of spinocerebellar paths. Pp. 339-380. In: IGGO, A. (Ed.) *Handbook of Sensory Physiology*. Vol. II. Somatosensory System, Berlin, Heidelberg, New York, Springer-Verlag, 1973.
  49. OSCARSSON, O. Functional units of the cerebellum-sagittal zones and microzones. *Trends Neurosci.*, **2**: 143-145, 1979.
  50. OSCARSSON, O. Functional organization of olivary projection to the cerebellar anterior lobe. Pp. 279-289. In: COURVILLE, J., DE MONTIGNY, C., and LAMARRE, Y., (Eds.) *The Inferior Olivary Nucleus: Anatomy and Physiology*. New York, Raven Press, 1980.
  51. PALAY, S.L. and CHAN-PALAY, V. *Cerebellar Cortex*. New York, Heidelberg, Berlin, Springer-Verlag, 1974.
  52. PALKOVITS, M., MAGYAR, P. and SZENTAGOTHAJ, J. Quantitative histological analysis of the cerebellar cortex in the cat. I. Number and arrangement in space of the Purkinje cells. *Brain Res.*, **32**: 1-13, 1971.
  53. ROSINA, A. and PROVINI, L. Longitudinal and topographical organization of the olivary projection to the cat ansiform lobule. *Neurosci.*, **7**: 2657-2676, 1982.
  54. ROSINA, A. and PROVINI, L. Somatotopy of climbing fiber branching to the cerebellar cortex in cat. *Brain Res.*, **289**: 45-63, 1983.
  55. ROSINA, A. and PROVINI, L. Spatial distribution of axon collaterals of single inferior olive neurons. *J. comp. Neurol.*, **256**: 317-328, 1987.
  56. TROTT, J.R. The olivocerebellar input to the medial and lateral halves of the C<sub>1</sub> and C<sub>3</sub> zones of the cat anterior lobe. Pp. 20-25. In: STRATA, P., (Ed.) *The Olivocerebellar System in Motor Control, Exp. Brain Res.* Berlin, Springer-Verlag, 1989.
  57. TROTT, J.R. The olivocerebellar and corticonuclear projections of forelimb and hind-limb related regions of the C<sub>1</sub> zone in the cat. *Europ. J. Neurosci.*, **1**: 105, 1989.
  58. TROTT, J.R., APPS, R. and ARMSTRONG, D.M. Topographical organization within the cerebellar nucleocortical projection to the paravermal cortex of lobule Vb/c in the cat. *Exp. Brain Res.*, 1989, in press.
  59. TROTT, J.R. and ARMSTRONG, D.M. The cerebellar corticonuclear projection from lobule Vb/c of the cat anterior lobe: a combined electrophysiological and autoradiographic



- study. I. Projections from the intermediate zone. *Exp. Brain Res.*, **66**: 318-338, 1987.
60. TROTT J.R. and ARMSTRONG, D.M. Olivocorticonuclear organization within lobule V of the anterior lobe of the cat cerebellum. Pp. 222-238. In: KING J.S., *New Concepts in Cerebellar Neurobiology*, New York, Alan R. Liss, 1987.
  61. VOOGD, J., *The Cerebellum of the Cat*. Thesis, Assen, Van Gorcum, 1964.
  62. VOOGD J. The importance of fiber connections in the comparative anatomy of the mammalian cerebellum. Pp. 493-451. In: LLINÁS R. (Ed.) *Neurobiology of cerebellar evolution and development*. Amer. Med. Assoc., 1969.
  63. VOOGD J. The olivocerebellar projection in the cat. In: PALAY, S.L. and CHAN-PALAY, V. (Eds.) *The Cerebellum: New Vistas. Exp Brain Res.*, Suppl. **6**: 134-161. Berlin, Heidelberg, New York, Springer, 1982.
  64. VOOGD, J., HESS, D.T. and MARANI, E. The parasagittal zonation of the cerebellar cortex in cat and monkey: Topography, distribution of acetylcholinesterase and development. Pp. 183-220. In: KING J.S. (Ed.) *New Concepts in Cerebellar Neurobiology*. New York, Alan R. Liss, 1987.
  65. WALBERG, F. and BRODAL, A. The longitudinal zonal pattern in the paramedian lobule of the cat's cerebellum. An analysis based in a correlation of recent HRP data with results of studies with other methods. *J. comp. Neurol.*, **187**: 581-588, 1979.